

KNIFE-GATE VALVES

K SERIES

24/04/2013

UNIDIRECTIONAL Knife Gate Valve

- Unidirectional knife gate valve.
- One-piece cast body with guides to support gate and seat wedges.
- Provides high flow rates with low pressure drop.
- Various seat and packing materials available.
- Face-to-face dimension in accordance with CMO standard.
- It has an arrow on the body indicating the flow direction.

General Applications:

This knife gate valve is suitable for liquids that contain a maximum of 5% suspended solids. If it is used for dry solids in gravity feed applications it should be installed with the arrow on the body pointing in the opposite direction to the flow. Designed for applications such as:

- Paper Industry
- Mining
- Silo emptying
- Chemical plants
- Pumping
- Food Industry
- Sewage treatment

Sizes: ND50 to ND2000 (larger sizes on request).

Working Pressure:

- ND50 to ND150: 10kg/cm²
- ND200: 8kg/cm²
- ND250 to ND300: 6kg/cm²
- ND350 to ND400: 5kg/cm²
- ND450 to ND600: 3kg/cm²
- ND700 to ND1400: 2kg/cm²

These pressures must be applied to the valve in the direction of the arrow marked on the valve's body. Due to the valve's design with gate support guides, 30% of these pressures can be applied in the opposite direction to the arrow.

Standard Flanges: DIN PN10 and ANSI B16.5 (class 150)

Other Common Flanges: DIN PN 6 DIN PN 16 DIN PN25
 BS "D" and "E" ANSI 150 Others on request

Directives:

- Machinery Directive: **DIR 2006/42/EC (MACHINERY)**
- Pressure Equipment Directive: **DIR 97/23/EC (PED) ART.3, P.3**
- Potential Explosive Atmospheres Directive: **DIR 94/9/EC (ATEX) CAT.3 ZONE 2 and 22 GD** For further information on categories and zones please contact the CMO Technical-Commercial Dept.

Quality Dossier:

- All valves are tested hydrostatically at CMO and material and test certificates can be provided.
- Body test = working pressure x 1.5.
- Seat test = working pressure x 1.1.

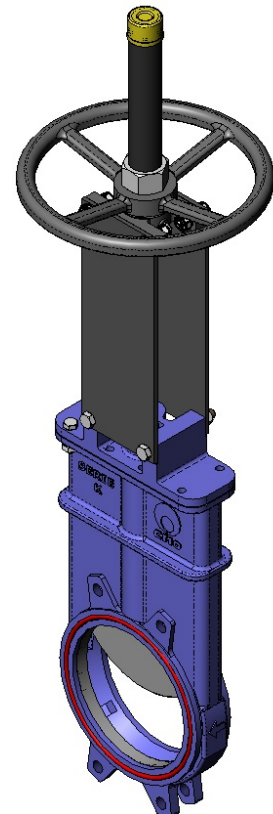

Fig. 1

C.M.O.

Amategui Aldea 142, 20400 Txarama-Tolosa (SPAIN)

TEC-K.EN05

Tel. Nacional: 902.40.80.50 Fax: 902.40.80.51 / Tel. Internacional: 34.943.67.33.99 Fax: 34.943.67.24.40

cmo@cmo.es <http://www.cmo.es>

Page 1

KNIFE-GATE VALVES

K SERIES

Advantages of CMO's "K Model" compared to similar products

When a knife gate valve remains open for long periods of time and the body's internal walls are parallel a very large torque is required to close it. The inside of the Model K's body is conically shaped, providing greater space. This way, when the valve is closed the solids stored inside it can be easily removed.

This valve is defined as unidirectional and these valves are normally at risk of the gate bending due to counter-pressure. This cannot happen with the CMO valve because it contains internal guides that support the knife gate and allow it to work under counter-pressure of 30% of the maximum working pressure, without the knife gate bending.

The stem protection hood is independent from the handwheel securing nut, this means the hood can be disassembled without the need to release the handwheel. This advantage allows regular maintenance operations to be performed, such as lubricating the stem, etc.

The stem on the CMO valve is made of 18/8 stainless steel. This is another added advantage, as some manufacturers produce it with 13% chrome and it gets rusty very quickly. The handwheel is made of GJS-500 nodular cast iron. Some manufacturers produce them in normal cast iron which can lead to breakages in the event of very high operating torque or knocks.

The yoke is has a compact design with the bronze actuator nut protected in a sealed and lubricated box. This makes it possible to move the valve with a key, even without the handwheel (in other manufacturers' products this is not possible).

The pneumatic actuator's upper and lower covers are made of GJS-400 nodular cast iron, making them highly shock resistant. This characteristic is essential in pneumatic actuators.

The pneumatic cylinder's o-ring seals are commercial products and can be purchased worldwide. This means it is not necessary to contact CMO every time a seal is required.

POS.	DESCRIPTION	GJL-250	CF8M
1	BODY	GJL-250	CF8M
2	GATE	AISI-304	AISI-316
3	COVER	GJL-250	CF8M
4	SEAT SEAL	CARDBOARD	CARDBOARD
5	SOCKET	NYLON	NYLON
6	STOP WASHER	AISI-304	AISI-316
7	INSIDE O-RING	NITRILE	NITRILE
8	OUTSIDE O-RING	NITRILE	NITRILE
9	O-RING	NITRILE	NITRILE
10	SEAT	RCH 1000	RCH 1000
11	SUPPORT PLATE	S275JR	S275JR
12	SCREW	5.6 ZINC	A-2
13	WASHER	5.6 ZINC	A-2
14	NUT	5.6 ZINC	A-2
15	SCREW	5.6 ZINC	A-4
16	WASHER	5.6 ZINC	A-4
17	NUT	5.6 ZINC	A-4
18	SEAL	EPDM	EPDM
19	RING	AISI-316	AISI-316

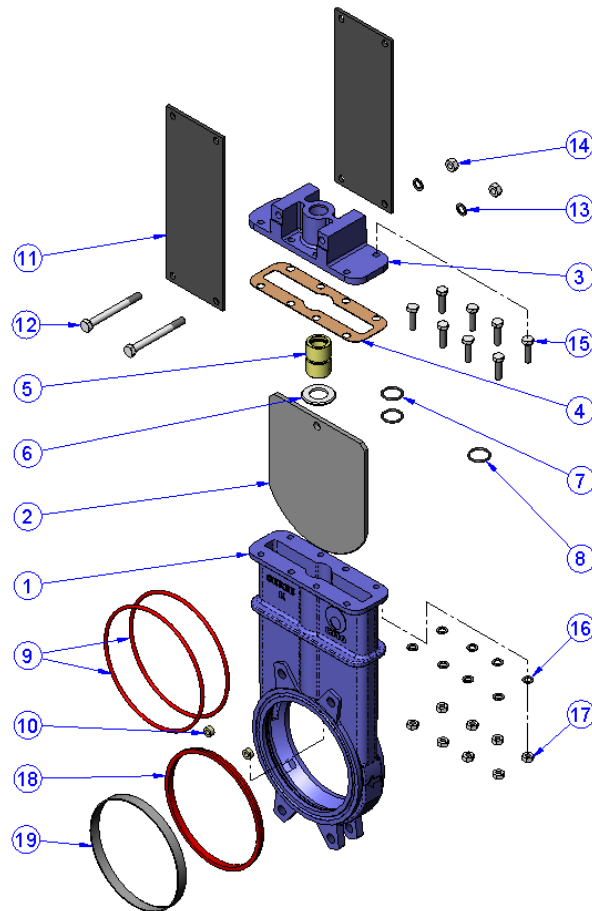

Fig. 2

Table 1

C.M.O.

Amategui Aldea 142, 20400 Txarama-Tolosa (SPAIN)

TEC-K.EN05

Tel. Nacional: 902.40.80.50 Fax: 902.40.80.51 / Tel. Internacional: 34.943.67.33.99 Fax: 34.943.67.24.40

cmo@cmo.es <http://www.cmo.es>

Page 2

DESIGN CHARACTERISTICS

1- BODY

Unidirectional knife gate valve. One-piece cast body with guides to support gate and seat wedges. For diameters greater than ND1200 the body is machine-welded with the necessary reinforcements to resist the maximum working pressure.

Full port designed to provide high flow rates with low pressure drop.

The body's internal design prevents any build up of solids in the seat area.

The standard manufacturing materials are GJL-250 cast iron and CF8M stainless steel. Other materials, such as GJS-500 nodular cast iron, A216WCB carbon steel and stainless steel alloys (AISI316Ti, Duplex, 254SMO, Uranus B6...) are available on request. As standard, iron or carbon steel valves are painted with an anti-corrosive protection of 80 microns of EPOXY (colour RAL 5015). Other types of anti-corrosive protections are available on request.

2- GATE

The standard manufacturing materials are AISI304 stainless steel in valves with iron body and AISI316 stainless steel in valves with CF8M body. Other materials or combinations can be supplied on request.

The gate is polished on both sides to provide a smooth contact surface with the resilient seat. At the same time, the gate is rounded to prevent the seat from being cut. Different degrees of polishing, anti-abrasion treatments and modifications are available to adapt the valves to the customer's requirements.

3- SEAT: (watertight)

Six types of seats are available according to the working application:

-Seat 1: Metal / metal seat. This type of seat does not include any kind of resilient seat and the estimated leakage (considering water as the test fluid) is 1.5% of the pipe flow.

-Seat 2: Standard soft-seated valve. This type of seat includes a resilient seat which is fixed to the inside of the body via an AISI316 stainless steel retaining ring.

-Seat 3: Soft-seated valve with reinforced socket. This type of seat includes a resilient seat which is fixed to the inside of the body via an AISI316 stainless steel retaining ring with two functions (to protect the valve from abrasion and clean the gate when working with solids that can stick to it).

-Seats 4, 5 and 6: The same as seats 1, 2 and 3 but including a deflector. The deflector is a cone-shaped ring located at the valve's entrance with two functions (to protect the valve from abrasion and guide the flow to the centre of the valve).

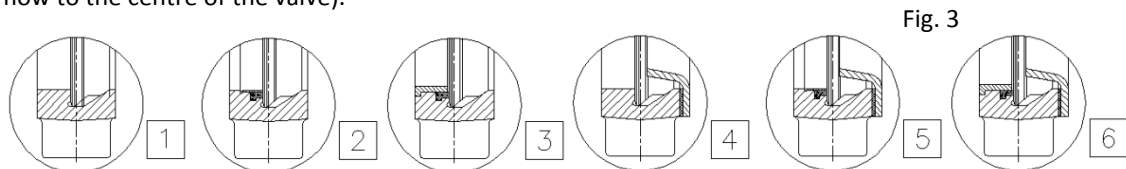

Note: Three materials are available for the reinforced socket and the deflector (CA-15 steel, CF8M and Ni-hard).

KNIFE-GATE VALVES

K SERIES

Resilient seat materials

EPDM

This is the standard resilient seat fitted on CMO valves. It can be used in many applications, however, it is generally used for water and products diluted in water at temperatures no higher than 90°C*. It can also be used with abrasive products and it provides the valve with 100% watertight integrity.

NITRILE

It is used in fluids containing fats or oils at temperatures no higher than 90°C*. It provides the valve with 100% watertight integrity.

VITON

Suitable for corrosive applications and continuous high temperatures of up to 190°C and peaks of 210°C. It provides the valve with 100% watertight integrity.

SILICONE

Mainly used in the food industry and for pharmaceutical products with temperatures no higher than 200°C. It provides the valve with 100% watertight integrity.

PTFE

Suitable for corrosive applications and pH between 2 and 12. Does not provide the valve with 100% watertight integrity. Estimated leakage: 0.5% of the tube flow.

 **Note:** In some applications other types of resilient materials are used, such as hypalon, butile or natural rubber. Please contact us if you require one of these materials.

4- PACKING

The packing is the area of the valve where the greatest watertight integrity must be reached to avoid leakages to the atmosphere, in the CMO K valves, this area is between the body bonnet and the rod. There are two types of packing:

- **Socket with o-rings:** This packing (Fig.4) achieves watertight integrity by inserting a socket between the body and the rod. This socket is limited at the top by the cover and at the bottom by a washer, it also has two internal seals in contact with the rod and another external one in contact with the body, to ensure watertight integrity.

This system is recommended for valves that operate with water. See Table 2 for the different types of seal materials.

- **Standard Packing:** CMO's standard packing is composed of three lines with a specially designed EPDM O-ring in the middle which provides watertight integrity between the body and the gate, preventing any type of leakage to the atmosphere. It is located in an easily accessible place and can be replaced without dismantling the valve from the pipeline. Below we indicate various types of packing available according to the application in which the valve is located:

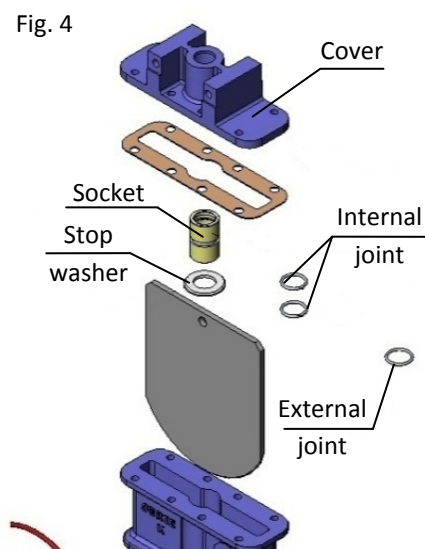

KNIFE-GATE VALVES

K SERIES

GREASED COTTON (Recommended for hydraulic services): This packing is composed of braided cotton fibres soaked in grease both inside and out. It is for general use in hydraulic applications in both pumps and valves.

DRY COTTON: This packing is composed of cotton fibres. It is for general use in hydraulic applications with solids.

COTTON + PTFE: This packing is composed of braided cotton fibres soaked in PTFE both inside and out. It is for general use in hydraulic applications in both pumps and valves.

SYNTHETIC + PTFE: This packing is composed of braided synthetic fibres soaked in PTFE both inside and out. It is for general use in hydraulic applications in both pumps and valves and in all types of fluids, especially corrosive ones, including concentrated and oxidising oils. It is also used in liquids with solid particles in suspension.

GRAPHITE: This packing is composed of high-purity graphite fibres. A diagonal braiding system is used and it is impregnated with graphite and lubricant which helps to reduce porosity and improve operation. It has a wide range of applications as graphite is resistant to steam, water, oils, solvents, alkali and most acids.

CERAMIC FIBRE: This packing is composed of ceramic material fibres. Its main applications are with air or gas at high temperatures and low pressures.

SEAT/SEALS			PACKING			
Material	Max. T. (°C)	Applications	Material	P(bar)	Max. T. (°C)	pH
Metal/Metal	>250	High T./Low watertight integ.	Greased cotton	10	100	6-8
EPDM (E)	90 *	Mineral acids and oils	Dry cotton (AS)	0.5	100	6-8
Nitrile (N)	90 *	Hydrocarbons, oils and greases	Cotton + PTFE	30	120	6-8
Viton (V)	200	Hydrocarbons and solvents	Synthetic + PTFE	100	-200+270	0-14
Silicone (S)	200	Food Products	Graphite	40	650	0-14
PTFE (T)	250	Corrosion resistant	Ceramic Fibre	0.3	1400	0-14

NOTE: More details and other materials available on request.

* → EPDM and nitrile: is possible until serving temperature Max.: 120°C under request.

Table 2

5- STEM

The stem on the CMO valve is made of 18/8 stainless steel. This characteristic provides high resistance and excellent corrosion-resistant properties.

The valve design can be rising stem or non-rising stem. When rising stem is required a stem hood is supplied to protect the stem from contact with dust and dirt, as well as keeping it lubricated.

6- PACKING GLAND

The packing gland allows uniform force and pressure to be applied to the packing to ensure watertight integrity.

As standard, valves with cast iron body include steel packing glands, whilst valves with stainless steel body have stainless steel packing glands.

7- ACTUATORS

All types of actuators can be supplied, with the advantage that the CMO design is fully interchangeable.

This design allows the customer to change the actuators themselves and normally no extra assembly accessories are required. In the event any accessory is required, CMO will supply it.



KNIFE-GATE VALVES

K SERIES

Manual:

Handwheel with rising stem
Handwheel with non-rising stem
Chainwheel
Lever
Gear Box
Others (square nut,...)

Automatic:

Electric actuator
Pneumatic cylinder
Hydraulic cylinder

A design characteristic of CMO S.L. valves is that all actuators are interchangeable.

Wide Range of Accessories Available:

Mechanical stops
Locking devices
Emergency manual actuators
Solenoid valves
Positioners
Limit switches
Proximity switches
Floor stands (Fig. 5)
...

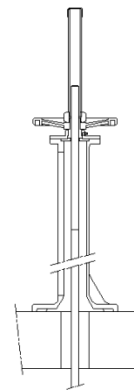
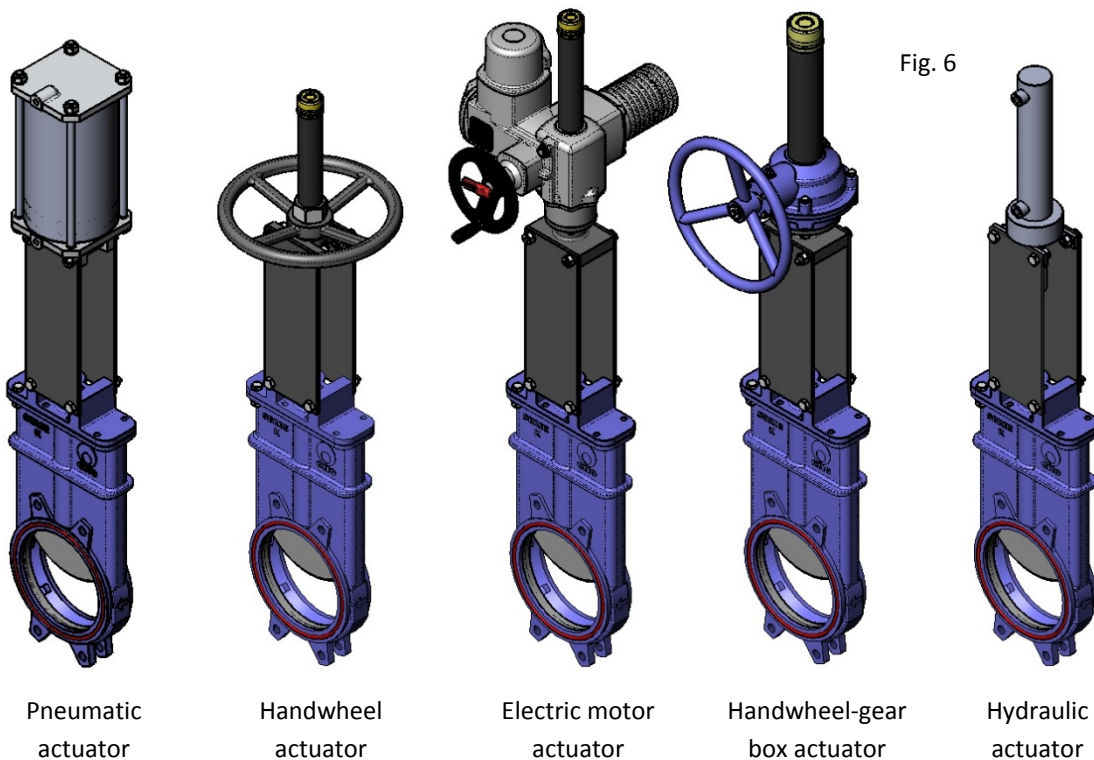

Fig. 5

Stem extensions have also been developed, allowing the actuator to be located far away from the valve, to suit all needs.

Please consult our technicians beforehand.



Pneumatic
actuator

Handwheel
actuator

Electric motor
actuator

Handwheel-gear
box actuator

Hydraulic
actuator

KNIFE-GATE VALVES

K SERIES

ACCESSORIES AND OPTIONS

Different types of accessories are available to adapt the valve to specific working conditions such as:

-Mirror Polished Gate: The mirror polished gate is especially recommended in the food industry and, as standard, in applications in which solids can stick to the gate. It is an alternative to ensure the solids slide off and do not stick to the gate.

-PTFE Lined Gate: As with the mirror polished gate, it improves the valve's resistance to products that can stick to the gate.

-Stellited Gate: Stellite is added to the gate's lower edge to protect it from abrasion.

-Scraper in the Packing: Its function is to clean the gate during the opening movement and prevent possible damage to the packing.

-Air Injection in the Packing Gland: By injecting air in the packing, an air chamber is created which improves the watertight integrity.

-Heating Jacket: Recommended when the fluid can harden and solidify inside the valve's body. An external jacket keeps the body temperature constant, preventing the fluid from solidifying.

-Flushing Holes in Body (Fig. 7): Several holes can be drilled in the body to flush air, steam or other fluids out in order to clean the valve seat before sealing.

-Mechanical Limit Switches, Inductive Switches and Positioners: Limit switches or inductive switches are installed to indicate precise valve position, as well as positioners to indicate continuous position.

-Solenoid Valves: They distribute the air to the pneumatic actuators.

-Connection Boxes, Wiring and Pneumatic Piping: Fully assembled units can be supplied with all the necessary accessories.

-Stroke Limiting Mechanical Stops:

-Mechanical Locking Device: It mechanically locks the valve in a set position for long periods of time.

-Emergency Manual Actuator (Hand Wheel /Gear Box): Allows manual operation of the valve in the event of power or air failure.

-Triangular (V-Notch) and Pentagonal Diaphragm with Indication Rule (Fig. 8): Recommended for applications in which flow regulation is required.

Allows flow control according to the valve's opening percentage.

-Interchangeable Actuators: All actuators are easily interchangeable.

-Epoxy Coating: All cast iron and carbon steel bodies and components on CMO valves are EPOXY coated, giving the valves great resistance to corrosion and an excellent finish. CMO's standard colour is blue, RAL-5015.

-Gate Safety Protection: In accordance with European Safety Standards ("EC" marking), CMO automated valves are equipped with gate guards, to prevent any objects from being accidentally caught in the gate.

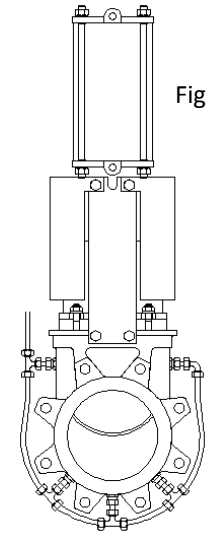

Fig. 7

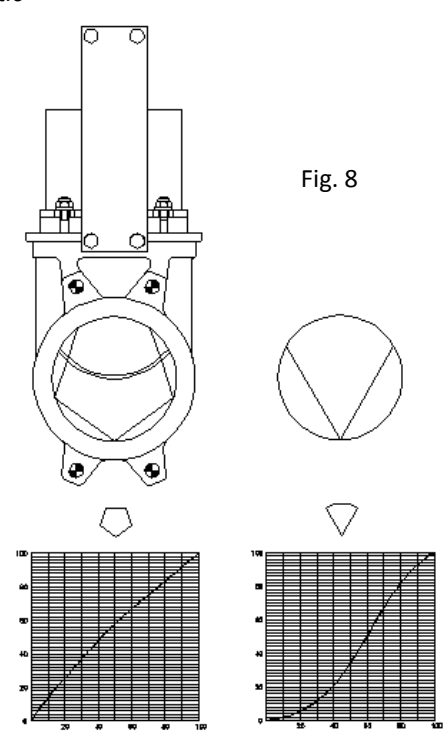

Fig. 8

VERTICAL: MAXIMUM FLOW %
HORIZONTAL: VALVE OPENING %



KNIFE-GATE VALVES

K SERIES

TYPES OF EXTENSION

When the valve needs to be operated from a distance, the following different types of actuators can be fitted:

1 - Extension: Floor Stand.

This extension is achieved by coupling a rod to the stem. The desired extension length is achieved by defining the length of the rod. A floor stand is normally installed to support the actuator.

The definition variables are as follows:

H1: Distance from the valve's centre to the base of the stand.

d1: Separation from the wall to the end of the connecting flange.

Characteristics:

- It can be coupled to any type of actuator.
- A stem support-guide (Fig. 10) is recommended every 1.5 m.
- The standard floor stand is 800mm high (Fig. 9). Other floor stand measurements available on request:
- A position indicator can be fitted to determine the valve's percentage of opening.
- Tilting stand available on request (Fig. 11).

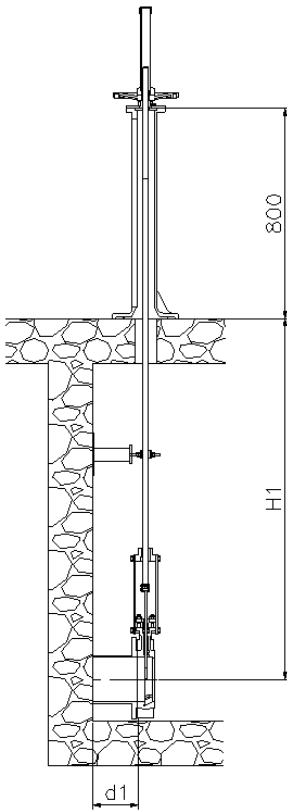

Fig. 9

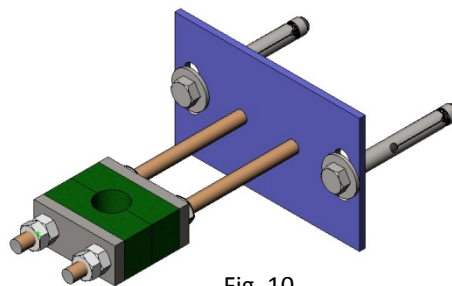

Fig. 10

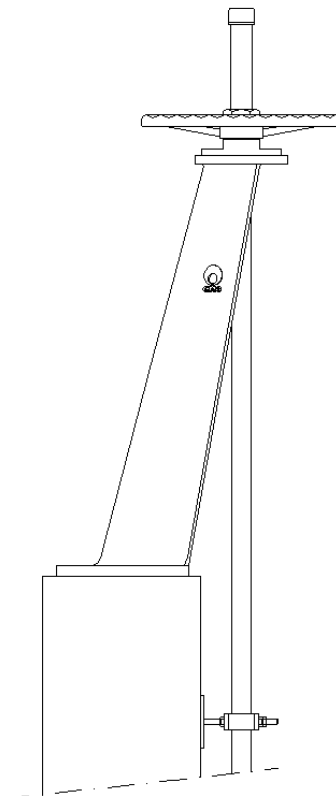

Fig. 11

COMPONENTS LIST	
Component	Standard Version
Stem AISI 304	AISI 303
Rod	AISI 304
Support-guide	EPOXY coated carbon steel
Slide	Nylon
Stand	EPOXY coated GJS-500

Table 3



KNIFE-GATE VALVES

K SERIES

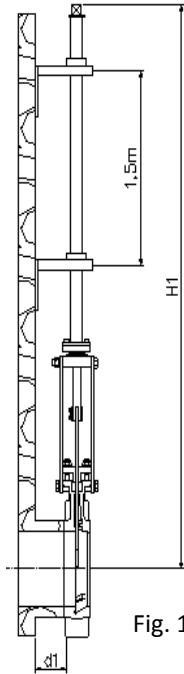

Fig. 12

2 - Extension: Pipe (Fig. 12)

Consists of raising the actuator. The pipe will rotate in the same direction as the handwheel when the valve is operated. The valve always remains at the same height.

The definition variables are as follows:

H1: Distance from the valve's centre to the base of the stand.

d1: Separation from the wall to the end of the connecting flange.

Characteristics:

- Standard actuators: Handwheel and "Square Nut"
- A pipe support-guide is recommended every 1.5m.
- The standard materials are: EPOXY coated carbon steel and stainless steel.

3 - Extension: Extended Support Plates (Fig. 13)

When a short extension is required, it can be achieved by extending the support plates. An intermediate yoke can be fitted to reinforce the support plates' structure.

Fig. 13

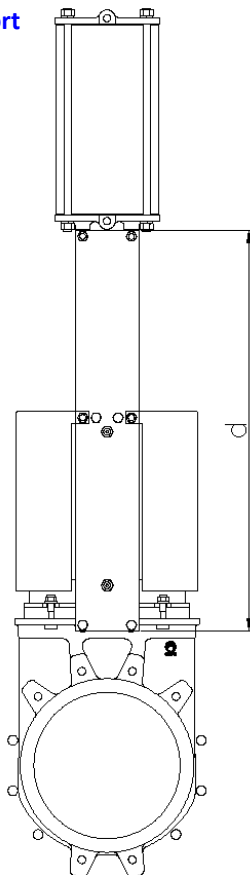
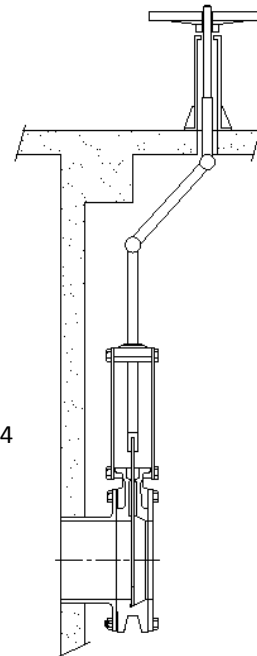

Fig. 14



4 - Extension: Universal Joint (Fig. 14)

If the valve and the actuator are not in correct alignment, the problem can be resolved by fitting a universal joint.



KNIFE-GATE VALVES

K SERIES

HANDWHEEL with Rising Stem

- **B = Max. width** of the valve (without actuator).
- **D = Max. height** of the valve (without actuator).

- Options:

- Locking devices.
- Extensions: stand, pipe, plates...
- ND higher than those give in the table.

- Actuator including:

- Handwheel.
- Stem.
- Nut.
- Stem protection hood.

- Available: ND50 to ND1200, other ND on request.

- From DN600 the actuator is with gears.

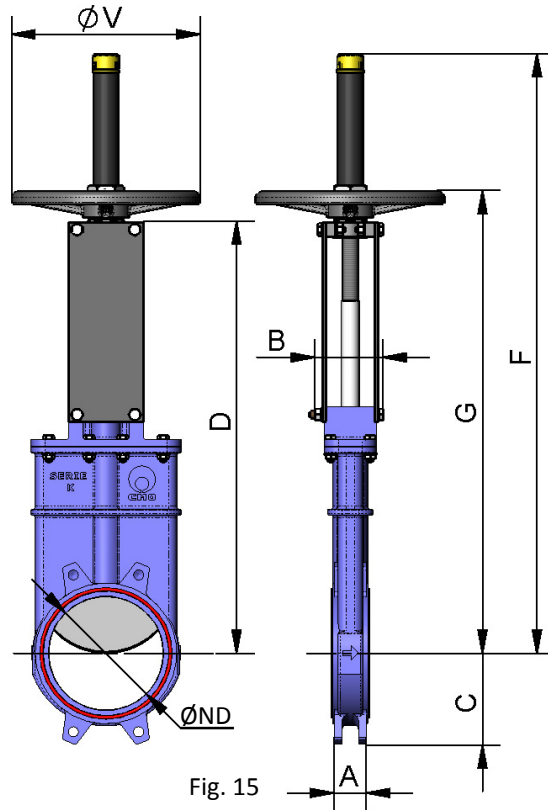

Fig. 15

ND	ΔP (Kg/cm ²)	DRAW (Nw)	TORQUE (Nm)	A	B	C	D	F	G	ϕV
50	10	815	1.86	40	91	61	323	492	362	225
65	10	1375	3.14	40	91	68	362	531	401	225
80	10	2083	4.76	50	91	91	404	573	443	225
100	10	3252	7.43	50	91	104	453	622	492	225
125	10	5080	11.6	50	101	118	511	730	550	225
150	10	5134	11.7	60	101	130	574	793	613	225
200	8	9138	26.1	60	118	159	745	1036	798	325
250	6	10227	29.2	70	118	196	880	1271	933	325
300	6	14748	42.1	70	118	230	1005	1396	1058	380
350	5	16064	62.3	96	290	254	1141	1681	1250	450
400	5	21042	81.6	100	290	287	1266	1806	1375	450
450	3	20043	77.7	106	290	304	1393	2033	1502	450
500	3	24883	96.5	110	290	340	1529	2169	1638	450
600	3	36081	139.9	110	290	398	1782	2522	1891	450
700	2	39945	180.1	110	320	453	2105	--	--	--
800	2	43493	237.8	110	320	503	2376	--	--	--
900	2	55024	300.9	110	320	583	2655	--	--	--
1000	2	68580	374.9	110	320	613	2935	--	--	--
1200	2	99025	642.5	150	340	728	3440	--	--	--

table 4



KNIFE-GATE VALVES

K SERIES

HANDWHEEL with Non-Rising Stem

- Suitable when no size limitations exist.
- **J = Max. width** of the valve (without actuator).
- **D = Max. height** of the valve (without actuator).
- Options:
 - Square nut.
 - Locking devices.
 - Extensions: stand, pipe, plates...
 - ND higher than those give in the table.
- Actuator including:
 - Handwheel.
 - Stem.
 - Guide bearings on the yoke.
 - Nut.
- Available: ND50 to ND2000, other ND on request.
- From DN600 the actuator is with gears.

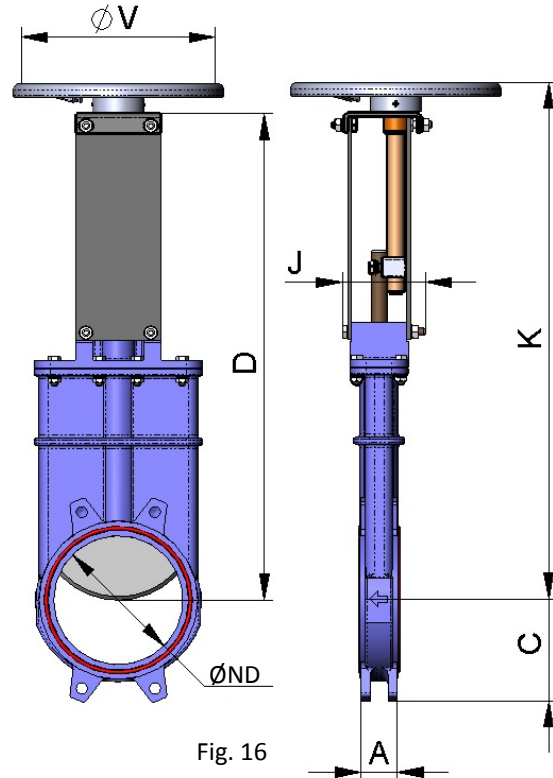

Fig. 16

ND	ΔP (Kg/cm ²)	DRAW (Nw)	TORQUE (Nm)	A	C	D	J	K	ϕV
50	10	815	1.86	40	61	323	101	362	225
65	10	1375	3.14	40	68	362	101	401	225
80	10	2083	4.76	50	91	404	101	443	225
100	10	3252	7.43	50	104	453	101	492	225
125	10	5080	11.6	50	118	511	111	550	225
150	10	5134	11.7	60	130	574	111	613	225
200	8	9138	26.1	60	159	745	128	798	325
250	6	10227	29.2	70	196	880	128	933	325
300	6	14748	42.1	70	230	1005	128	1058	380
350	5	16064	62.3	96	254	1141	305	1220	450
400	5	21042	81.6	100	287	1266	305	1345	450
450	3	20043	77.7	106	304	1393	305	1472	450
500	3	24883	96.5	110	340	1529	305	1608	450
600	3	36081	139.9	110	398	1782	305	1861	450
700	2	39945	180.1	110	453	2105	335	--	--
800	2	43493	237.8	110	503	2376	335	--	--
900	2	55024	300.9	110	583	2655	335	--	--
1000	2	68580	374.9	110	613	2935	335	--	--
1200	2	99025	642.5	150	728	3440	355	--	--

table 5

C.M.O.

Amategui Aldea 142, 20400 Txarama-Tolosa (SPAIN)

TEC-K.EN05

Tel. Nacional: 902.40.80.50 Fax: 902.40.80.51 / Tel. Internacional: 34.943.67.33.99 Fax: 34.943.67.24.40

cmo@cmo.es <http://www.cmo.es>

Page 11



KNIFE-GATE VALVES

K SERIES

CHAINWHEEL

- Widely used in raised installations with difficult access, the handwheel is fitted in vertical position.
- **B = Max. width** of the valve (without actuator)
D = Max. height of the valve (without actuator)
- Options:
 - Locking devices.
 - Extensions: stand, pipe, plates...
 - Non-rising stem.
 - ND higher than those give in the table.
- Including:
 - Handwheel.
 - Stem.
 - Nut.
 - Hood.
- Available: ND50 to ND1200, other ND on request.
- From DN600 the actuator is with gears, see * in table.

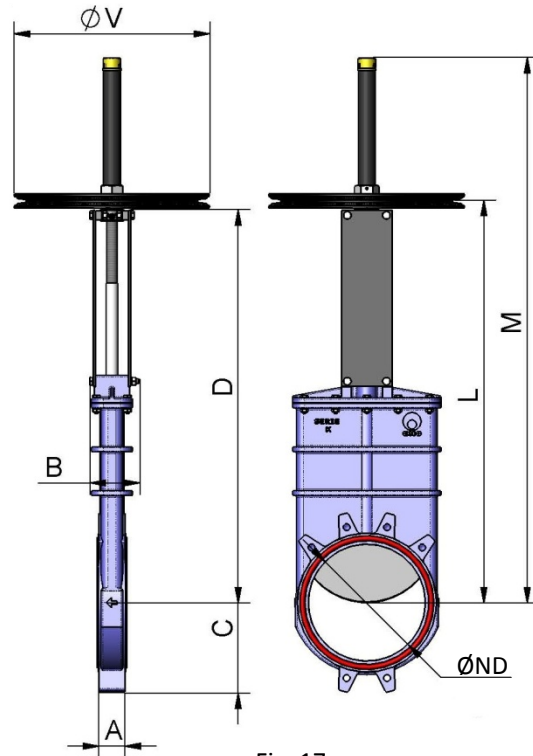

Fig. 17

ND	ΔP (Kg/cm ²)	DRAW (Nw)	TORQUE (Nm)	A	B	C	D	L	M	ϕV
50	10	815	1.86	40	91	61	323	343	443	225
65	10	1375	3.14	40	91	68	362	382	502	225
80	10	2083	4.76	50	91	91	404	424	564	225
100	10	3252	7.43	50	91	104	453	473	633	225
125	10	5080	11.6	50	101	118	511	531	701	225
150	10	5134	11.7	60	101	130	574	594	794	225
200	8	9138	26.1	60	118	159	745	765	1045	300
250	6	10227	29.2	70	118	196	880	900	1200	300
300	6	14748	42.1	70	118	230	1005	1025	1375	300
350	5	16064	62.3	96	290	254	1141	1161	1580	402
400	5	21042	81.6	100	290	287	1266	1286	1760	402
450	3	20043	77.7	106	290	304	1393	1413	1940	402
500	3	24883	96.5	110	290	340	1529	1550	2120	402
600	3	36081	139.9	110	290	398	1782	1802	2470	402
700	2	39945	180.1	110	320	453	2105	2205	3035	402*
800	2	43493	237.8	110	320	503	2376	2476	3406	402*
900	2	55024	300.9	110	320	583	2655	2755	3785	402*
1000	2	68580	374.9	110	320	613	2935	3035	4165	402*
1200	2	99025	642.5	150	340	728	3440	3540	4870	402*

table 6

C.M.O.

Amategui Aldea 142, 20400 Txarama-Tolosa (SPAIN)

TEC-K.EN05

Tel. Nacional: 902.40.80.50 Fax: 902.40.80.51 / Tel. Internacional: 34.943.67.33.99 Fax: 34.943.67.24.40

cmo@cmo.es <http://www.cmo.es>

Page 12



KNIFE-GATE VALVES

K SERIES

LEVER

- It is a fast actuator.
- **B = Max. width** of the valve (without actuator).
D = Max. height of the valve (without actuator).
- The actuator includes:
 - Lever.
 - Rod.
 - Guide bearing.
 - External limiting switches to maintain the position.
- Available: ND50 to ND300, other ND on request.

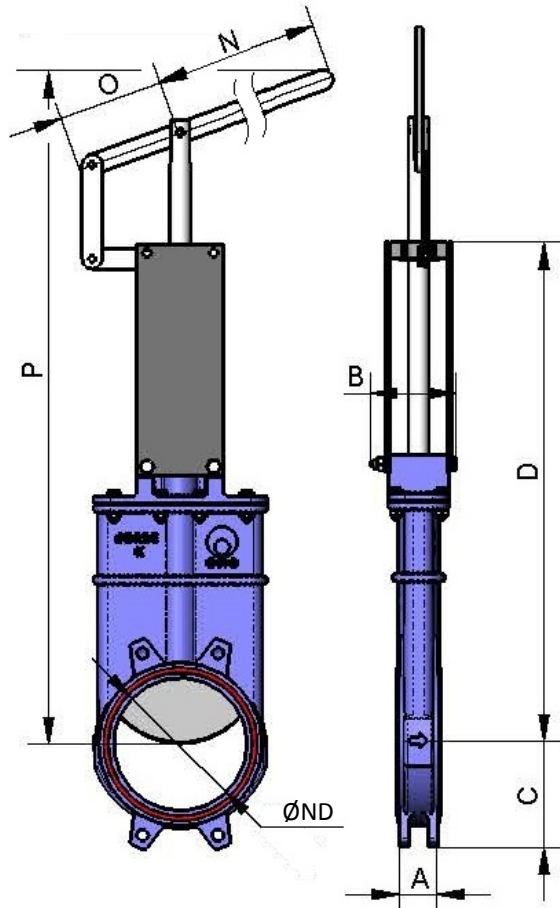

Fig. 18

ND	ΔP (Kg/cm ²)	DRAW/ (Nw)	A	B	C	D	N	O	P
50	10	815	40	91	61	323	325	155	471
65	10	1375	40	91	68	362	325	155	530
80	10	2083	50	91	91	404	325	155	617
100	10	3252	50	91	104	453	325	155	733
125	10	5080	50	101	118	511	425	155	869
150	10	5134	60	101	130	574	425	155	1006
200	8	9138	60	118	159	745	620	290	1318
250	6	10227	70	118	196	880	620	290	1599
300	6	14748	70	118	230	1005	620	290	1873

table 7



KNIFE-GATE VALVES

K SERIES

GEAR BOX

- It is recommendable for DN greater than 600.
- **B = Max. width** of the valve (without actuator).
D = Max. height of the valve (without actuator).
- Options:
 - Chainwheel.
 - Locking devices.
 - Extensions: stand, pipe, plates...
 - **Non-rising stem.**
- Actuator including:
 - Cone-shaped gear box - Stem
 - Handwheel - Yoke
- Standard ratio = 4 to 1.
- Available: ND50 to ND2000, other ND on request.

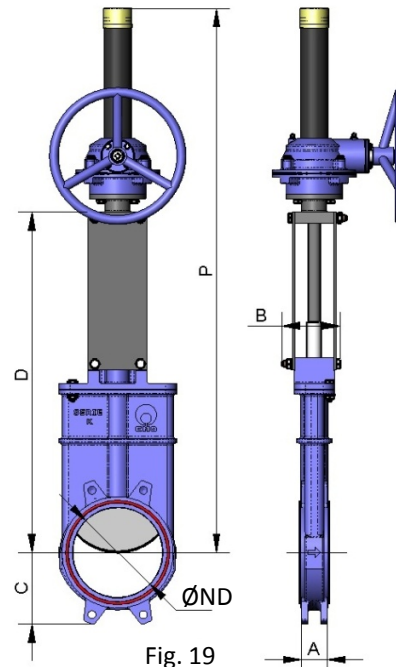

ND	ΔP (Kg/cm ²)	DRAW (Nw)	TORQUE (Nm)	A	B	C	D	P
50	10	815	1.86	40	91	61	323	620
65	10	1375	3.14	40	91	68	362	659
80	10	2083	4.76	50	91	91	404	701
100	10	3252	7.43	50	91	104	453	750
125	10	5080	11.6	50	101	118	511	808
150	10	5134	11.7	60	101	130	574	871
200	8	9138	26.1	60	118	159	745	1164
250	6	10227	29.2	70	118	196	880	1299
300	6	14748	42.1	70	118	230	1005	1424
350	5	16064	62.3	96	290	254	1141	1680
400	5	21042	81.6	100	290	287	1266	1805
450	3	20043	77.7	106	290	304	1393	2082
500	3	24883	96.5	110	290	340	1529	2218
600	3	36081	139.9	110	290	398	1782	2471
700	2	39945	180.1	110	320	453	2105	2905
800	2	43493	237.8	110	320	503	2376	3385
900	2	55024	300.9	110	320	583	2655	3787
1000	2	68580	374.9	110	320	613	2935	4190
1100	2	83196	539.8	150	340	670	3187	4537
1200	2	99026	642.5	150	340	728	3440	4880
1300	2	117653	763.3	150	390	787	3730	5280
1400	2	136884	888.1	150	390	837	4019	5669
1500	2	158591	1190.6	170	426	890	4217	5967
1600	2	180653	1518.6	170	426	957	--	--
1700	2	204052	1715.2	190	440	1010	--	--
1800	2	230715	1939.4	190	440	1057	--	--
1900	2	258472	2172.6	210	480	1110	--	--
2000	2	289155	2760.9	210	480	1162	--	--

table 8

C.M.O.

Amategui Aldea 142, 20400 Txarama-Tolosa (SPAIN)

TEC-K.EN05

Tel. Nacional: 902.40.80.50 Fax: 902.40.80.51 / Tel. Internacional: 34.943.67.33.99 Fax: 34.943.67.24.40

cmo@cmo.es <http://www.cmo.es>

Page 14

KNIFE-GATE VALVES

K SERIES

DOUBLE-ACTING PNEUMATIC CYLINDER

- CMO double-acting pneumatic actuators are designed to work at a pressure between 6 and 10 kg/cm².
- 10 Kg/cm² is the maximum admissible air pressure. For air pressures below 6 Kg/cm² please consult manufacturer.
- For ND50 to ND200 valves, the cylinder's jacket and covers are made of aluminium, the rod of AISI304, the piston of rubber-coated steel and the O-ring seals are made of nitrile.
- For valves larger than ND200 the covers are made of nodular cast iron or carbon steel.
- On request, we can also supply the actuator made entirely of stainless steel, especially for installation in corrosive atmospheres.
- **B = Max. width** of the valve (without actuator).
D = Max. height of the valve (without actuator).
- Available: ND50 to ND1200, other ND on request.

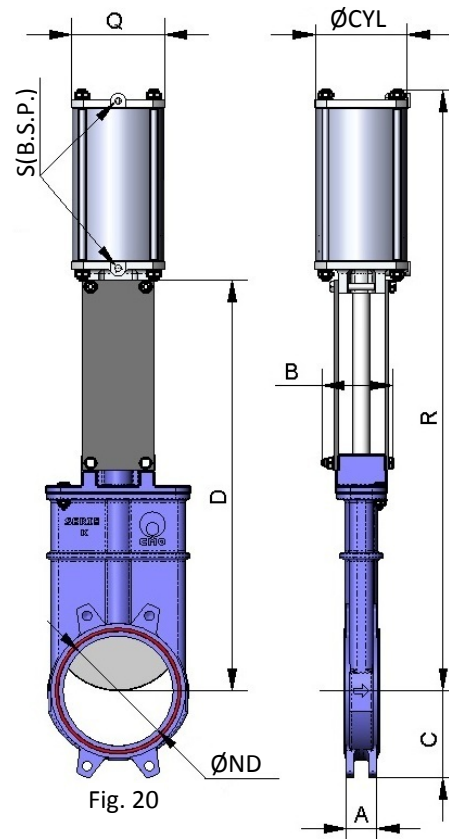

ND	ΔP (Kg/cm ²)	DRAW (Nw)	A	B	C	D	R	Q	Ø CYL.	Ø ROD	S (B.S.P.)
50	10	815	40	91	61	323	498	96	80	20	1/4"
65	10	1375	40	91	68	362	550	96	80	20	1/4"
80	10	2083	50	91	91	404	608	96	80	20	1/4"
100	10	3252	50	91	104	453	680	115	100	20	1/4"
125	10	5080	50	101	118	511	774	138	125	25	1/4"
150	10	5134	60	101	130	574	866	138	125	25	1/4"
200	8	9138	60	118	159	745	1090	175	160	30	1/4"
250	6	10227	70	118	196	880	1287	218	200	30	3/8"
300	6	14748	70	118	230	1005	1462	218	200	30	3/8"
350	5	16064	96	290	254	1141	1724	270	250	40	3/8"
400	5	21042	100	290	287	1266	1899	270	250	40	3/8"
450	3	20043	106	290	304	1393	2081	382	300	45	1/2"
500	3	24883	110	290	340	1529	2267	382	300	45	1/2"
600	3	36081	110	290	398	1782	2620	382	300	45	1/2"
700	2	39945	110	320	453	2105	3087	426	350	45	1/2"
800	2	43493	110	320	503	2376	3456	426	350	45	1/2"
900	2	55024	110	320	583	2655	3855	538	400	50	1/2"
1000	*	*	110	320	613	2935	4220	552	450	50	3/4"
1100	*	*	150	340	670	3187	4586	552	450	50	3/4"
1200	*	*	150	340	728	3440	4939	552	450	50	3/4"

* → Consult

table 9

C.M.O.

Amategui Aldea 142, 20400 Txarama-Tolosa (SPAIN)

TEC-K.EN05

Tel. Nacional: 902.40.80.50 Fax: 902.40.80.51 / Tel. Internacional: 34.943.67.33.99 Fax: 34.943.67.24.40

cmo@cmo.es <http://www.cmo.es>

Page 15



KNIFE-GATE VALVES

K SERIES

SINGLE-ACTING PNEUMATIC CYLINDER

- CMO single-acting pneumatic actuators are designed to work at a pressure between 6 and 10 kg/cm².
- 10 Kg/cm² is the maximum admissible air pressure. For air pressures below 6 Kg/cm² please consult manufacturer.
- Available for opening or closing in case of failure (spring opening or closing).
- The jacket is made of aluminium, the covers of nodular cast iron or carbon steel, the rod of AISI304, the piston of rubber-coated steel, the O-ring seals of nitrile and the spring is made of steel.
- The **actuator** design is **spring** activated for valves with diameters **up to ND300**. For larger diameters the actuator contains a double-acting cylinder and an air tank which stores the volume of air necessary to
* → Consult last movement in the event of a f. table 9
- **B = Max. width** of the valve (without actuator).
D = Max. height of the valve (without actuator).
- Available: ND 50 to ND 1200, other ND on request.

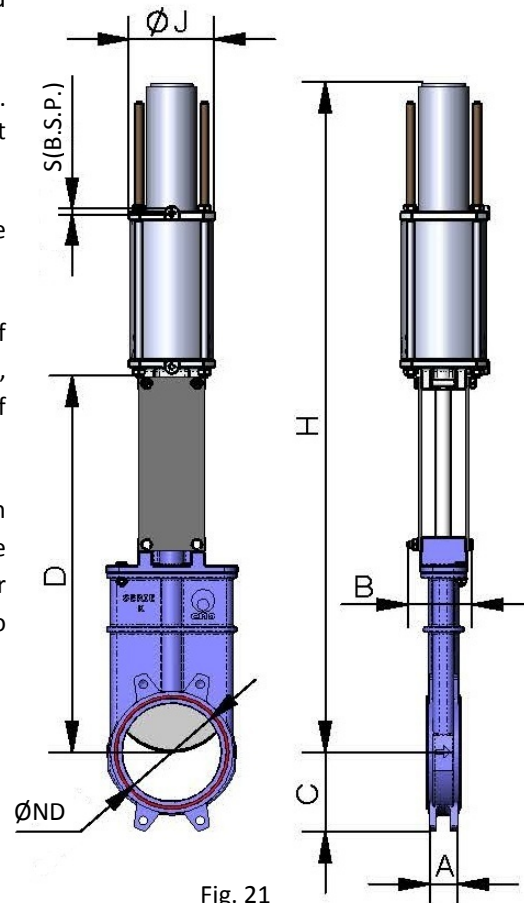

Fig. 21

Note: Please see the "CMO Pneumatic Actuators" catalogue if you require further information.

ND	ΔP (Kg/cm ²)	DRAW (Nw)	A	B	C	D	H	ØJ	Ø CYL.	Ø ROD	S (B.S.P.)
50	10	815	40	91	61	323	804	135	125	25	1/4"
65	10	1375	40	91	68	362	856	135	125	25	1/4"
80	10	2083	50	91	91	404	914	135	125	25	1/4"
100	10	3252	50	91	104	453	986	135	125	25	1/4"
125	10	5080	50	101	118	511	1048	170	160	30	1/4"
150	10	5134	60	101	130	574	1140	170	160	30	1/4"
200	8	9138	60	118	159	745	1610	215	200	30	3/8"
250	6	10227	70	118	196	880	2115	270	250	40	3/8"
300	6	14748	70	118	230	1005	2290	270	250	40	3/8"

table 10



KNIFE-GATE VALVES

K SERIES

ELECTRIC ACTUATOR

- This actuator is automatic and includes the following parts:
 - Electric motor
 - Stem
 - Yoke
- The electric motor includes:
 - Emergency manual handwheel.
 - Limit switches.
 - Torque switches.
- Options:
 - Different types and brands.
 - Non-rising stem.
- ISO 5210 / DIN 3338 Flanges.
- Available: ND50 to ND2000, other ND on request.
- From DN500 the motor is assisted with a gear box.

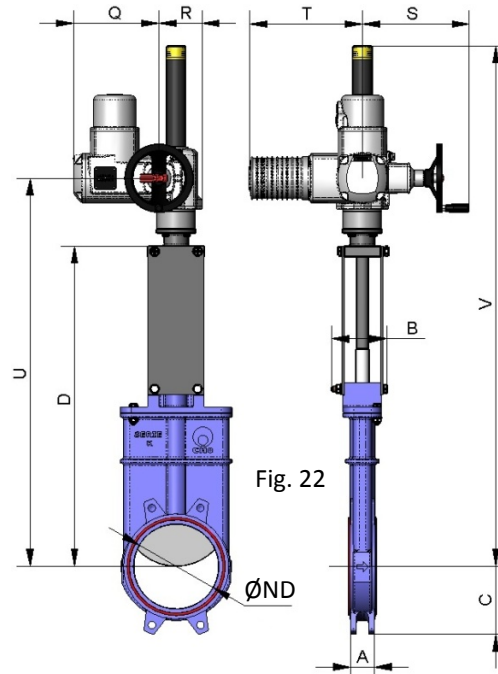

ND	ΔP (Kg/cm ²)	DRAW (Nw)	TORQUE (Nm)	A	B	C	D	Q	R	S	T	U	V
50	10	815	1.86	40	91	61	323	197	102	234	265	441	573
65	10	1375	3.14	40	91	68	362	197	102	234	265	480	627
80	10	2083	4.76	50	91	91	404	197	102	234	265	522	684
100	10	3252	7.43	50	91	104	453	197	102	234	265	571	753
125	10	5080	11.6	50	101	118	511	197	102	234	265	629	836
150	10	5134	11.7	60	101	130	574	197	102	234	265	692	765
200	8	9138	26.1	60	118	159	745	197	102	234	265	863	1145
250	6	10227	29.2	70	118	196	880	197	102	234	265	998	1330
300	6	14748	42.1	70	118	230	1005	197	102	234	265	1123	1505
350	5	16064	62.3	96	290	254	1141	197	115	256	282	1271	1711
400	5	21042	81.6	100	290	287	1266	197	115	256	282	1396	1886
450	3	20043	77.7	106	290	304	1393	222	153	325	385	1523	2079
500	3	24883	96.5	110	290	340	1529	222	153	325	385	1659	2249
600	3	36081	139.9	110	290	398	1782	222	153	325	385	1937	2643
700	2	39945	180.1	110	320	453	2105	222	153	325	385	2260	3066
800	2	43493	237.8	110	320	503	2376	222	153	332	385	2531	3437
900	2	55024	300.9	110	320	583	2655	222	153	332	385	2791	3651
1000	2	68580	374.9	110	320	613	2935	222	153	332	385	3071	4031
1100	2	83196	539.8	150	340	670	3187	227	195	355	510	3323	4422
1200	2	99026	642.5	150	340	728	3440	227	195	355	510	3576	4775
1300	2	117653	763.3	150	390	787	3730	227	195	355	510	3866	5165
1400	2	136884	888.1	150	390	837	4019	222	153	332	385	4192	5587
1500	2	158591	1190.6	170	426	890	4217	222	153	332	385	4390	5885
1600	2	180653	1518.6	170	426	957	--	227	195	355	510	--	--
1700	2	204052	1715.2	190	440	1010	--	227	195	355	510	--	--
1800	2	230715	1939.4	190	440	1057	--	227	195	355	510	--	--
1900	2	258472	2172.6	210	480	1110	--	227	195	355	510	--	--
2000	2	289155	2760.9	210	480	1162	--	227	195	355	510	--	--

table 11

C.M.O.

Amategui Aldea 142, 20400 Txarama-Tolosa (SPAIN)

TEC-K.EN05

Tel. Nacional: 902.40.80.50 Fax: 902.40.80.51 / Tel. Internacional: 34.943.67.33.99 Fax: 34.943.67.24.40

cmo@cmo.es <http://www.cmo.es>

Page 17

KNIFE-GATE VALVES

K SERIES

HYDRAULIC ACTUATOR (Oil pressure: 135 Kg/cm²)

- **B = Max. width** of the valve (without actuator)
- **D = Max. height** of the valve (without actuator)
- The hydraulic actuator includes:
 - Hydraulic cylinder.
 - Yoke.
- Available: ND50 to ND2000.
- Different types and brands available according to customer's requirements.

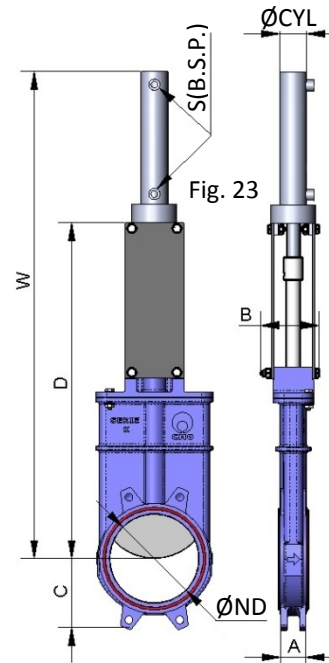

ND	ΔP (Kg/cm ²)	DRAW (Nw)	A	B	C	D	W	Ø CYL.	Ø ROD	S (B.S.P.)	Oil Cap. (dm ³)
50	10	815	40	91	61	323	479	25	18	3/8"	0,03
65	10	1375	40	91	68	362	533	25	18	3/8"	0,03
80	10	2083	50	91	91	404	590	25	18	3/8"	0,04
100	10	3252	50	91	104	453	659	32	22	3/8"	0,09
125	10	5080	50	101	118	511	742	32	22	3/8"	0,11
150	10	5134	60	101	130	574	830	40	28	3/8"	0,20
200	8	9138	60	118	159	745	1071	50	28	3/8"	0,42
250	6	10227	70	118	196	880	1266	50	28	3/8"	0,52
300	6	14748	70	118	230	1005	1454	50	28	3/8"	0,62
350	5	16064	96	290	254	1141	1640	50	28	3/8"	0,73
400	5	21042	100	290	287	1266	1815	63	36	3/8"	1,31
450	3	20043	106	290	304	1393	1992	63	36	3/8"	1,47
500	3	24883	110	290	340	1529	2197	63	36	3/8"	1,62
600	3	36081	110	290	398	1782	2550	80	45	3/8"	3,12
700	2	39945	110	320	453	2105	2994	80	45	3/8"	3,62
800	2	43493	110	320	503	2376	3365	100	56	1/2"	6,44
900	2	55024	110	320	583	2655	3744	100	56	1/2"	7,25
1000	2	68580	110	320	613	2935	4138	125	70	1/2"	10,25
1100	2	83196	150	340	670	3187	4490	125	70	1/2"	12,65
1200	2	99026	150	340	728	3440	4843	125	70	1/2"	15,05
1300	2	117653	150	390	787	3730	5285	160	70	1/2"	26,14
1400	2	136884	150	390	837	4019	5674	160	70	1/2"	28,65
1500	2	158591	170	426	890	4217	6014	160	70	1/2"	30,7
1600	2	180653	170	426	957	--	--	160	70	1/2"	32,7
1700	2	204052	190	440	1010	--	--	200	90	1/2"	53,41
1800	2	230715	190	440	1057	--	--	200	90	1/2"	57,35
1900	2	258472	210	480	1110	--	--	200	90	1/2"	60,27
2000	2	289155	210	480	1162	--	--	200	90	1/2"	63,65

table 12

C.M.O.

Amategui Aldea 142, 20400 Txarama-Tolosa (SPAIN)

TEC-K.EN05

Tel. Nacional: 902.40.80.50 Fax: 902.40.80.51 / Tel. Internacional: 34.943.67.33.99 Fax: 34.943.67.24.40

cmo@cmo.es <http://www.cmo.es>

Page 18



KNIFE-GATE VALVES

K SERIES

INFORMATION ON FLANGE DIMENSIONS

EN 1092-2 PN10

ND	ΔP (Kg/cm ²)	•	o	Metric	T	ϕK
50	10	4	-	M 16	10	125
65	10	4	-	M 16	10	145
80	10	4	4	M 16	12	160
100	10	4	4	M 16	12	180
125	10	4	4	M 16	12	210
150	10	4	4	M 20	17	240
200	8	4	4	M 20	16	295
250	6	6	6	M 20	19	350
300	6	6	6	M 20	19	400
350	5	10	6	M 20	28	460
400	5	10	6	M 24	28	515
450	3	14	6	M 24	28	565
500	3	14	6	M 24	34	620
600	3	14	6	M 27	26	725
700	2	16	8	M 27	25	840
800	2	16	8	M 30	22	950
900	2	20	8	M 30	21	1050
1000	2	20	8	M 33	21	1160
1100	2	20	12	M 33	30	1270
1200	2	20	12	M 36	30	1380
1300	2	20	12	M 36	35	1490
1400	2	24	12	M 39	35	1590
1500	2	24	12	M 39	28	1700
1600	2	28	12	M 45	40	1820
1700	2	30	14	M 45	40	1920
1800	2	30	14	M 45	36	2020
1900	2	32	16	M 45	45	2120
2000	2	32	16	M 45	45	2230

table 13

ANSI B16, class 150

ND	ΔP (Kg/cm ²)	•	o	R UNC	T	ϕK
2"	10	4	-	5/8"	10	120,6
2 1/2"	10	4	-	5/8"	10	139,7
3"	10	4	-	5/8"	12	152,4
4"	10	4	4	5/8"	12	190,5
5"	10	4	4	3/4"	12	215,9
6"	10	4	4	3/4"	17	241,3
8"	8	4	4	3/4"	16	298,4
10"	6	6	6	7/8"	19	361,9
12"	6	6	6	7/8"	19	431,8
14"	5	8	4	1"	28	476,2
16"	5	10	6	1"	28	539,7
18"	3	10	6	1 1/4"	28	577,8
20"	3	14	6	1 1/4"	34	635
24"	3	14	6	1 1/4"	26	749,3
28"	2	20	8	1 1/4"	25	863,6
30"	2	20	8	1 1/4"	22	914,4
32"	2	18	10	1 1/2"	21	977,9
36"	2	20	12	1 1/2"	21	1085,9
40"	2	24	12	1 1/2"	30	1200,2

table 14

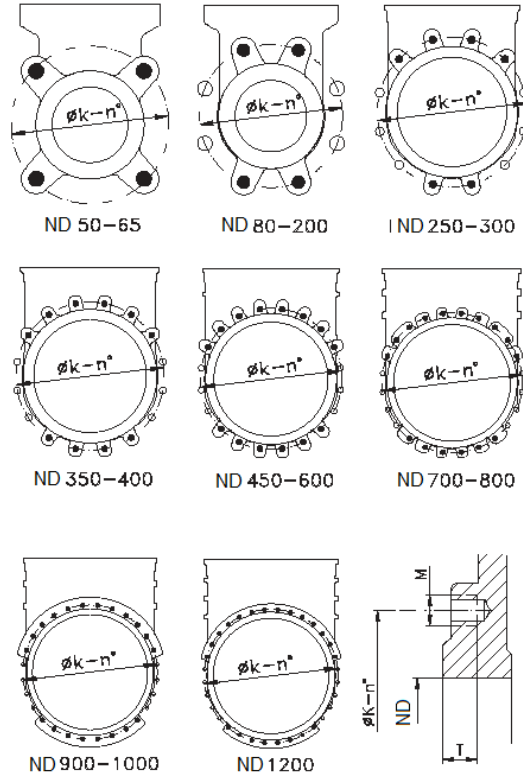

Fig. 24

- BLIND TAPED HOLES
- o THROUGH HOLE

