

GATE VALVES

D SERIES

23/04/2013

UNIDIRECTIONAL Gate Valve

- Unidirectional flanged gate valve (bidirectional option to order), designed for high pressure applications, with self-cleaning seal.
- Single piece die-cast body with screwed-down bonnet and wedges to guarantee the seal.
- Provides high flow rates with low pressure drop.
- Various seal and packing materials available.
- Face-to-face distance in accordance with CMO standard.
- It has an arrow on the body indicating the flow direction.

General Applications:

- The gate valve is suitable for working with clean liquids or liquids with a concentration of solids:
- Drying plants - Paper industry - Water Treatment
- Chemical Plants - Food sector - Mining
- Oil extraction - Sludge

Sizes: DN50 to DN2000 (larger sizes to order).

Working (ΔP): From PN 2.5 up to PN 100
Each valve is designed according to work conditions.

Boring: DIN PN10 and ANSI B16.5 (150 LB)

Other common flanges:

DIN PN 16	JIS Standard	Australian standard
DIN PN 6	DIN PN25	British Standard

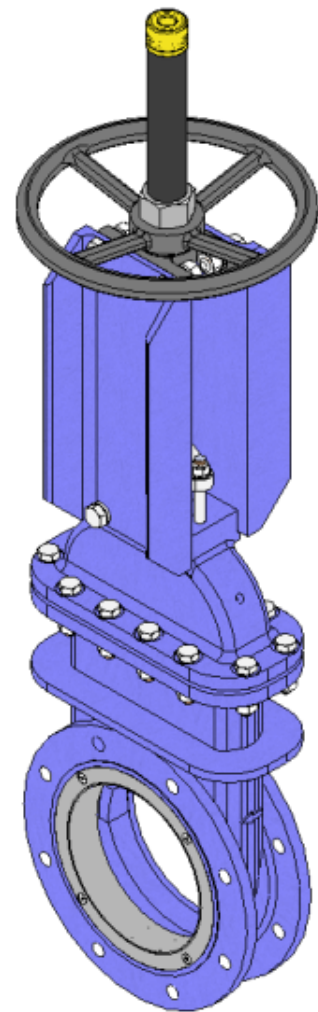

fig. 1

Directives:

- Machinery Directive: **DIR 2006/42/EC (MACHINERY)**
- Pressure Equipment Directive: **DIR 97/23/EC (PED) ART.3, P.3**
- Potentially Explosive Atmospheres Directive (optional): **DIR 94/9/EC (ATEX) CAT.3 ZONE 2 and 22 GD** , for information on categories and zones please contact CMO Technical-Sales Department.

Quality dossier:

- All valves are tested hydrostatically at CMO and material and test certificates can be provided.
- Body test = working pressure x 1.5.
- Seal test = working pressure x 1.1.

GATE VALVES

D SERIES

Advantages of CMO "D Model"

When a gate valve remains open for long periods of time and the body's internal walls are parallel a very large torque is required to close it. The inside of the **D** model body has a conical shape which provides more space; moreover, the width across flats in this type of valves is greater than standard, thus achieving more space. This way, when the valve is shut-off the solids stored inside it can be easily released.

This knife gate valve is defined as unidirectional and in this type of valves of other suppliers there is the risk of the gate bending due to the existence of counterpressure. This cannot happen with the CMO valve because it contains internal slides that support the gate and allow it to work under counterpressure of 30% of the maximum working pressure, without the gate becoming deformed. There is also option of making bidirectional **D** valves to order.

The stem protection hood is independent from the handwheel securing nut, this means the hood can be disassembled without the need to release the handwheel. This advantage allows regular maintenance operations to be performed, such as lubricating the stem, etc.

The CMO valve spindle is made of stainless steel 18/8. This is another added advantage, as some manufacturers supply it with 13% chromium, resulting in quick oxidation.

The operating wheel is manufactured in nodular cast GJS-500. Some manufacturers supply it in common cast-iron, which can lead to breakage in the event of very high operation torque or a bang. The yoke has a compact design with the bronze actuator nut protected in a sealed and lubricated box. This makes it possible to move the valve with a key, even without the handwheel (in other manufacturers' products this is not possible).

The pneumatic actuator's upper and lower covers are made of GJS-400 nodular cast iron, making them highly shock resistant. This characteristic is essential in pneumatic actuators.

The pneumatic cylinder's seals are commercial products and can be purchased worldwide. This means it is not necessary to contact CMO every time a seal is required.

STANDARD COMPONENTS LIST		
COMPONENT	STEEL VERSION	STAINLESS STEEL VERSION
1- Body	A216WCB	CF8M
2- Gate	AISI304	AISI316
3- Bonnet	A216WCB	CF8M
4 - Gland Flange	S275JR	AISI316
5- Gland bushing	AISI304	AISI316
6- Packing	SYNTH + PTFE	SYNTH + PTFE
7- Stem	AISI303	AISI303
8- Support plates	S275JR	S275JR
9- Seal	EPDM	EPDM
10- Ring	AISI304	AISI316
11- Yoke	GJS-500	GJS-500
12- Stem nut	BRONZE	BRONZE
13- Stopper Nut	STEEL	STEEL
14- Handwheel	GJS-500	GJS-500
15- Hood nut	5.6 ZINC	5.6 ZINC
16- Hood	STEEL	STEEL
17- Protection cap	PLASTIC	PLASTIC

table 1

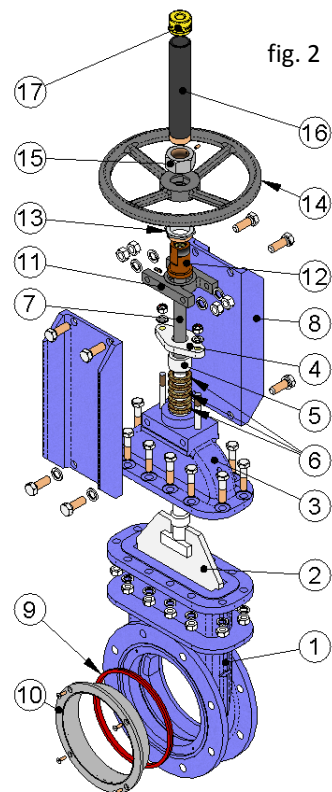

C.M.O.

Amategui Aldea 142, 20400 Txarama-Tolosa (SPAIN)

TEC-D.EN04

Tel. Nacional: 902.40.80.50 Fax: 902.40.80.51 / Tel. Internacional: 34.943.67.33.99 Fax: 34.943.67.24.40

cmo@cmo.es <http://www.cmo.es>

Page 2

GATE VALVES

D SERIES

DESIGN CHARACTERISTICS

1- BODY

Single piece (monobloc) die-cast body with screwed-down bonnet. The body has interior guides for optimum sliding of the gate and wedges for improved seal-tightness.

For diameters over DN1200, the body and the bonnet are mechanically welded with the reinforcements necessary to withstand the maximum working pressure.

Designed with full passage to provide large flows with small losses of load.

The internal design of the body prevents solids from being stored in the seal area, whilst the distance between flanges in this type of valves allows the solids to move freely inside the body.

The standard manufacturing materials are A216WCB carbon steel and CF8M stainless steel. Other materials such as GJS-500 and stainless steel alloys (AISI316Ti, Duplex, 254SMO, Uranus B6, etc) are available on request. As standard, carbon steel valves are painted with an anti-corrosive protection of 80 microns of EPOXY (colour RAL 5015). Other types of anti-corrosive protections are available to order.

2- GATE

The standard manufacturing materials are AISI304 stainless steel in valves with carbon steel body and AISI316 stainless steel in valves with CF8M body. Other materials or combinations can be supplied to order.

The gate is polished on both sides to provide a smooth contact surface with the resilient seal. At the same time, the gate is rounded to prevent the seal from being cut. Different degrees of polishing, anti-abrasion treatments and modifications are available to adapt the valves to the customer's requirements.

3- SEAT:

Four types of seats are available according to the working application:

-Seat 1: Standard metal / metal seat. This type of seat does not include any kind of resilient seal and the estimated leakage (considering water as the test fluid) is 1.5% of the pipe flow.

There is the option of a metal/metal seat with leakage in accordance with the Standard.

-Seat 2: Metal / rubber seat with ring. This type of seat includes a resilient seal which is fixed to the inside of the body by way of a stainless steel ring, which is screwed to the body in order to prevent it moving due to the high pressure.

- Seats 3 and 4: As seats 1 and 2 but including a deflector. The deflector is an O-ring located at the valve input with two functions: firstly to protect the valve from abrasion and secondly to guide the flow to the centre of the valve.

***Note:** Three materials are available for the deflector: Steel CA-15, CF8M and Ni-hard.

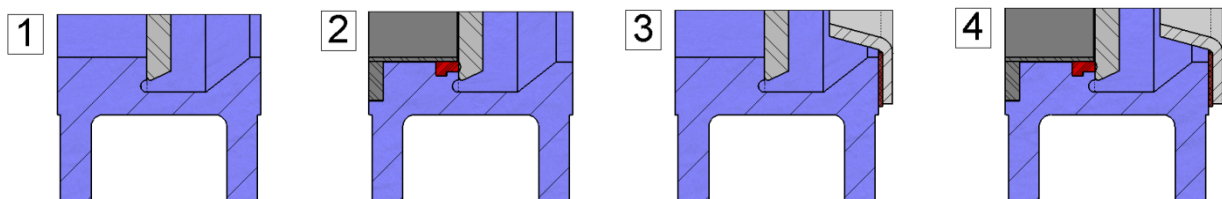

fig. 3

C.M.O.

Amategui Aldea 142, 20400 Txarama-Tolosa (SPAIN)

TEC-D.EN04

Tel. Nacional: 902.40.80.50 Fax: 902.40.80.51 / Tel. Internacional: 34.943.67.33.99 Fax: 34.943.67.24.40

cmo@cmo.es <http://www.cmo.es>

Page 3



GATE VALVES

D SERIES

Resilient seat materials

EPDM

This is the standard resilient seat fitted on CMO valves. It can be used in many applications, however, it is generally used for water and products diluted in water at temperatures no higher than 90°C*. It can also be used with abrasive products and it provides the valve with 100% watertight integrity.

NITRILE

It is used in fluids containing fats or oils at temperatures no higher than 90°C*. It provides the valve with 100% watertight integrity.

VITON

Suitable for corrosive applications and continuous high temperatures of up to 190°C and peaks of 210°C. It provides the valve with 100% watertight integrity.

SILICONE

Mainly used in the food industry and for pharmaceutical products with temperatures no higher than 200°C. It provides the valve with 100% watertight integrity.

PTFE

Suitable for corrosive applications and pH between 2 and 12. Does not provide the valve with 100% watertight integrity. Estimated leakage: 0.5% of the tube flow.

 **Note:** In some applications other types of resilient materials are used, such as hypalon, butile or natural rubber. Please contact us if you require one of these materials.

4- PACKING

CMO standard packing comprises several lines (from 4 to 6) of seal which provide seal-tightness between the bonnet and the spindle, preventing any type of leakage to the atmosphere. It is located in an easily accessible place and can be replaced without dismantling the valve from the pipeline. Below we indicate various types of packing available according to the use to be given to the valve:

GREASED COTTON (Recommended for hydraulic services)

This packing is composed of braided cotton fibres soaked in grease both inside and out. It is for general use in hydraulic applications in both pumps and valves.

DRY COTTON

This packing is composed of cotton fibres. It is for general use in hydraulic applications with solids.

COTTON + PTFE

This packing is composed of braided cotton fibres soaked in PTFE both inside and out. It is for general use in hydraulic applications in both pumps and valves.

SYNTHETIC + PTFE

This packing is composed of braided synthetic fibres soaked in PTFE both inside and out. It is for general use in hydraulic applications in both pumps and valves and in all types of fluids, especially corrosive ones, including concentrated and oxidising oils. It is also used in liquids with solid particles in suspension.

LUBRICATED PTFE

This is made with PTFE filaments and designed to work at great speed. It is braided with a diagonal system. Suitable for valves and pumps which work with almost all types of fluids, particularly with the most corrosive, such as oxidant and concentrated oils. It is also used in liquids with solid content.

GATE VALVES

D SERIES

GRAPHITE

This packing is composed of high-purity graphite fibres. A diagonal braiding system is used and it is impregnated with graphite and lubricant which helps to reduce porosity and improve operation.

It has a wide range of applications as graphite is resistant to steam, water, oils, solvents, alkali and most acids.

CERAMIC FIBRE

This packing is composed of ceramic material fibres. Its main applications are with air or gas at high temperatures and low pressures.

SEAT/SEALS			PACKING			
Material	Max. T. (°C)	Applications	Material	P(bar)	Max. T. (°C)	pH
Metal/Metal	>250	High temperatures	Greased cotton	10	100	6-8
EPDM (E)	90 *	Non-mineral oils, acids and water.	Dry cotton (AS)	0.5	100	6-8
Nitrile (N)	90 *	Hydrocarbons, oils and greases	Cotton + PTFE	30	120	6-8
Viton (V)	200	Hydrocarbons and solvents	SYNTHETIC + PTFE	100	-200+270	0-14
Silicone (S)	200	Food Products	Graphite	40	650	0-14
PTFE (T)	250	Resistant to corrosion	Ceramic Fibre	0.3	1400	0-14

NOTE: More details and other materials available to order.

* → EPDM and nitrile: is possible until serving temperature Max.: 120°C under request.

table 2

5- STEM

The CMO valve spindle is made of stainless steel 18/8. This characteristic makes it highly resistant and provides excellent properties against corrosion.

The valve design can be rising stem or non-rising stem. When a rising stem is required for the valve, a stem hood is supplied to protect the stem from contact with dust and dirt, besides keeping it lubricated.

6- PACKING GLAND

The packing gland flange, through the bushing, allows uniform pressure and force to be applied on the packing in order to guarantee seal tightness.

As standard, valves with steel body include a steel packing gland flange, while for valves with stainless steel body this is made of stainless steel. In both cases the packing bushing is common material, usually stainless steel.

7- ACTUATORS

All types of actuators can be supplied, with the advantage that, thanks to the CMO design, they are fully interchangeable. This design allows the customer to change the actuators themselves and no extra assembly accessories are required. A design characteristic of CMO valves is that all actuators are interchangeable.

Manual:

Handwheel with rising stem
Handwheel with non-rising stem
Chainwheel
Lever
Geared motor
Others (square nut, etc)

Automatic:

Electric actuator
Pneumatic cylinder
Hydraulic cylinder

GATE VALVES

D SERIES

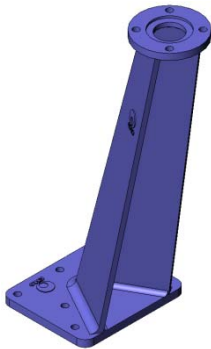

fig. 4

Wide range of accessories available:

- Mechanical stops
- Locking devices
- Emergency manual actuators
- Electrovalves
- Positioners
- Limit switches
- Proximity switches
- Straight floor stands (fig. 5)
- Leaning floor stand (fig. 4)
- Etc.

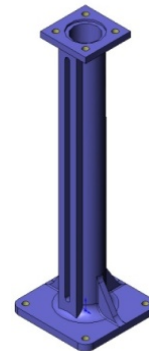

fig. 5

Stem extensions have also been developed, allowing the actuator to be located far away from the valve, to suit all needs. Please consult our technicians beforehand.

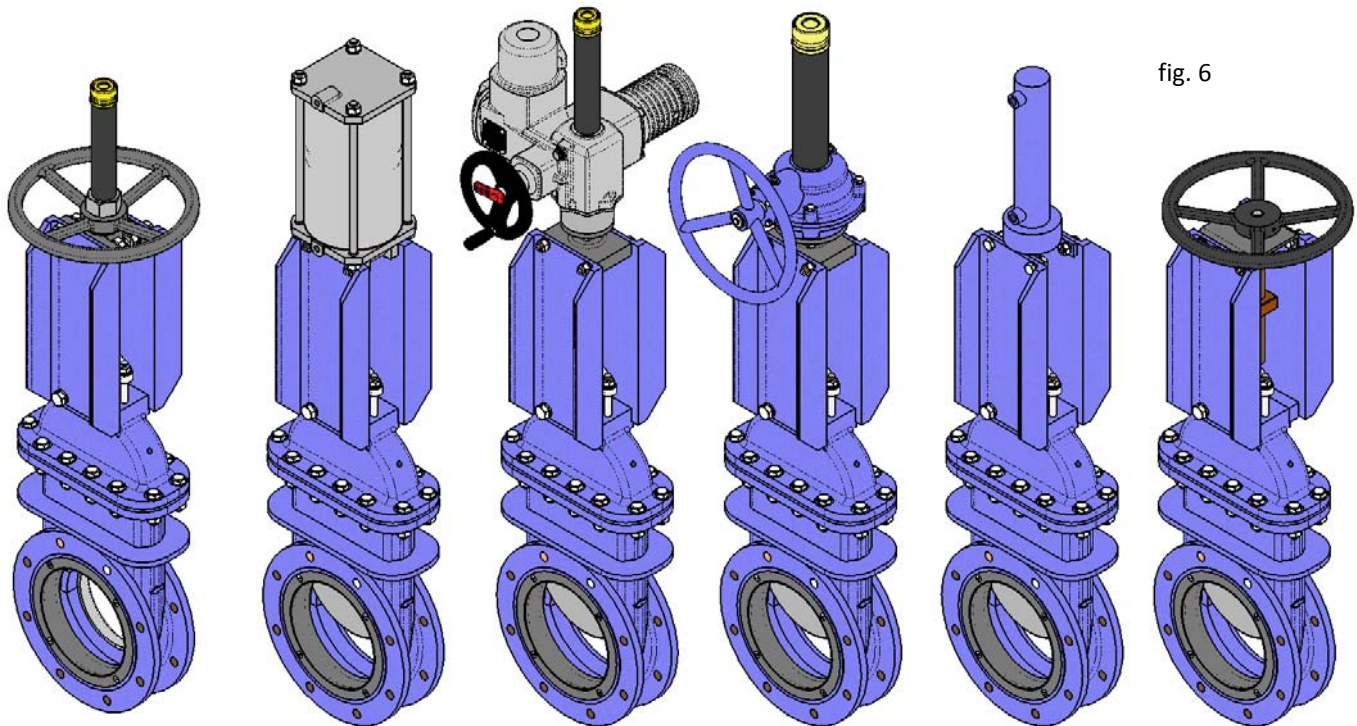

fig. 6

Handwheel with rising stem

Pneumatic actuator

Electric-motor actuator

Geared handwheel

Hydraulic actuator

Handwheel with NON-rising stem

ACCESSORIES AND OPTIONS

Different accessories are available to adapt the valve to specific working conditions such as:

Mirror polished gate:

The mirror polished gate is especially recommended in the food industry and, as standard, in applications in which solids can stick to the gate. It is an alternative to ensure the solids slide off and do not stick to the gate.

C.M.O.

Amategui Aldea 142, 20400 Txarama-Tolosa (SPAIN)

TEC-D.EN04

Tel. Nacional: 902.40.80.50 Fax: 902.40.80.51 / Tel. Internacional: 34.943.67.33.99 Fax: 34.943.67.24.40

cmo@cmo.es <http://www.cmo.es>

Page 6

GATE VALVES

D SERIES

PTFE lined gate:

As with the mirror polished gate, it improves the valve's resistance to products that can stick to the gate.

Stellited gate:

Stellite is added to the gate's internal circle to protect it from abrasion.

Scraper in the packing:

Its function is to clean the gate during the opening movement and prevent possible damage to the packing.

Air injections in the packing gland:

By injecting air in the packing, an air chamber is created which improves the seal-tightness.

Cased body:

Recommended in applications in which the fluid can harden and solidify inside the valve's body. An external jacket keeps the body temperature constant, preventing the fluid from solidifying.

Flushing holes in body:

Several holes are drilled in the body to flush air, steam or other fluids out with the aim of cleaning the valve seat before sealing.

Electrovalves (fig. 7):

For air distribution to pneumatic actuators.

Connection boxes, wiring and pneumatic piping:

Units supplied fully assembled with all the necessary accessories.

Mechanical limit switches, inductive switches and positioners:

Limit switches or inductive switches are installed to indicate precise valve position, as well as positioners to indicate continuous position (fig. 7).

Mechanical locking system:

Allows the valve to be mechanically locked in a set position for long periods.

Stroke limiting mechanical stops:

These allow the stroke to be mechanically adjusted, limiting the valve run.

Emergency manual actuator (hand wheel / gear box) (Fig. 7):

Allows manual operation of the valve in the event of power or air failure.

Triangular (V-Notch) and pentagonal diaphragm with indication rule:

Recommended for applications in which it is necessary to regulate the flow, it allows flow control according to the valve's opening percentage.

Interchangeable actuators:

All actuators are easily interchangeable.

Actuator or yoke support:

Made of EPOXY-coated steel (or stainless steel to order), its robust design gives it great rigidity in order to resist the most adverse operation conditions.

Epoxy coating:

All carbon steel components and bodies of CMO valves are EPOXY coated, giving the valves great resistance to corrosion and an excellent surface finish. CMO's standard colour is blue RAL-5015.

Bonnet:

Provides total seal-tightness to the outside, reducing the packing maintenance required.

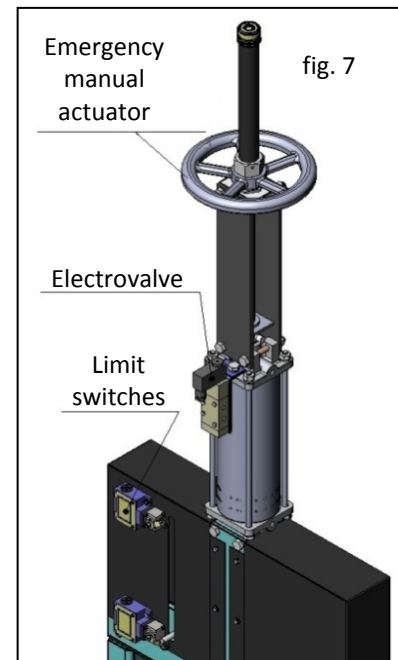



GATE VALVES

D SERIES

TYPES OF EXTENSION

When the valve needs to be operated from a distance, the following different types of actuators can be fitted:

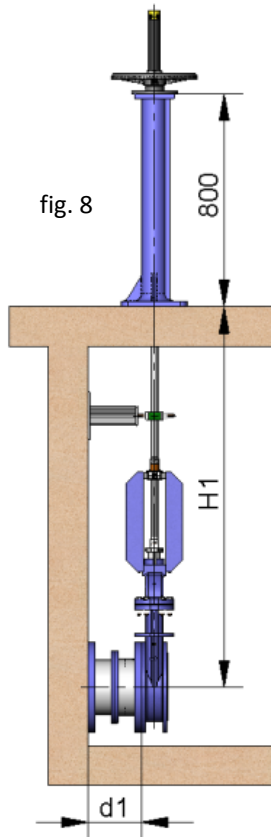

1- Extension: Floor Stand.

This extension is done by coupling a spindle to the stem. By defining the length of the spindle, the desired extension is achieved. A floor stand is normally installed to support the actuator.

The definition variables are as follows:

H1: Distance from the valve shaft to the base of the stand.

d1: Separation from the wall to the end of the connecting flange.

Characteristics:

- It can be coupled to any type of actuator.
- A stem support-guide is recommended (fig. 9) every 1.5 m.
- The standard floor stand is 800 mm high (fig. 8). Other floor stand measurements available to order.
- A position indicator can be fitted to determine the valve's percentage of opening.
- Possibility of leaning floor stand (fig. 10).

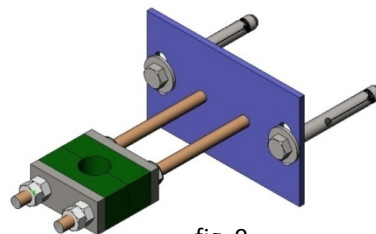

fig. 9

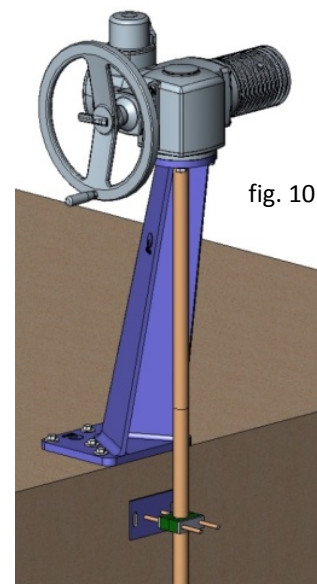

fig. 10

COMPONENTS LIST	
Component	Standard Version
Stem	AISI 303
Spindle	AISI 304
Support-Guide	Carbon steel with EPOXI coating
Slide	Nylon
Column	GJS-500 with EPOXY coating

table 3



GATE VALVES

D SERIES

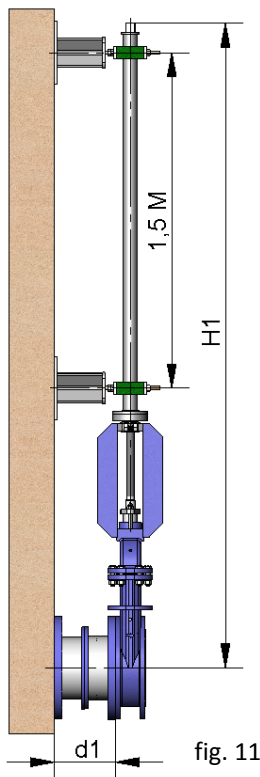

2 - Extension: Pipe (fig. 11)

Consists of raising the actuator. The pipe will rotate with the wheel or key when the valve is operated, although this will always remain at the same height.

The definition variables are as follows:

H1: Distance from the valve shaft to the desired height of the actuator.

d1: Separation from the wall to the end of the connecting flange.

Characteristics:

- Standard actuators: Handwheel and Square Nut.
- A pipe support-guide is recommended every 1.5m.
- The standard materials are: EPOXY coated carbon steel or stainless steel.

3 - Extension: Extended Support Plates (fig. 12)

When a short extension is required, it can be achieved by extending the support plates. An intermediate yoke can be fitted to reinforce the support plates' structure.

fig. 12

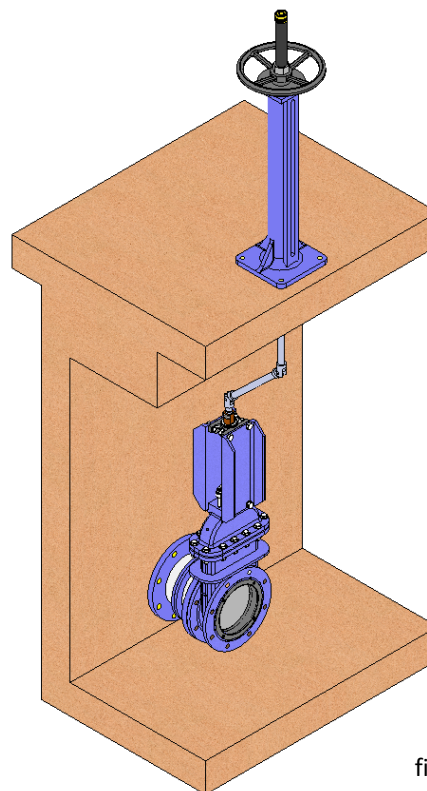
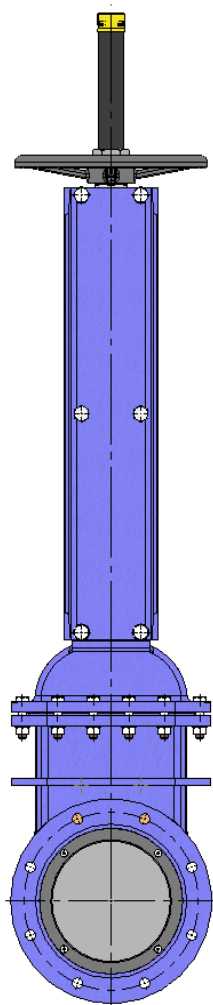

fig. 13

4 - Extension: Cardan joint (Fig. 13)

If the valve and the actuator are not in correct alignment, the problem can be resolved by fitting a universal joint.



GATE VALVES

D SERIES

HANDWHEEL with rising stem

- **B = Max. width** of the valve (without actuator)
- **D = Max. height** of the valve (without actuator).

- Options:

- Locking devices.
- Extensions: stand, pipe, plates,...
- DN higher than those shown in the table.

- Actuator comprising:

- Handwheel.
- Stem.
- Nut.
- Stem protection hood.

- Available: DN50 to DN2000, other DN to order.

- From DN350 the actuator is with geared motor.

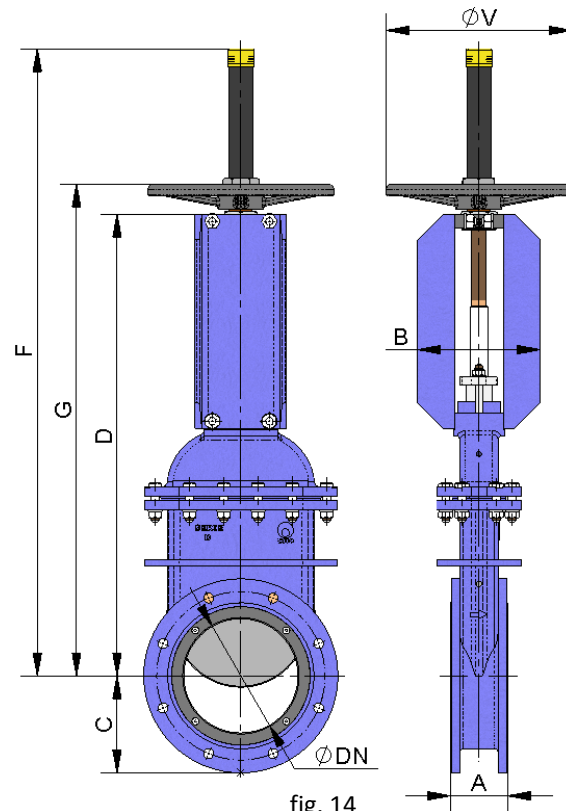

fig. 14

DN	ΔP (Kg/cm ²)	DRAW (Nw)	TORQUE (Nm)	A	B	C	D	G	F	ϕV
50	10	830	1,91	70	106	83	330	369	498	225
65	10	1400	3,22	70	106	93	365	404	534	225
80	10	2120	4,9	70	106	100	401	440	570	225
100	10	3320	7,61	70	160	110	468	507	637	225
125	10	5180	11,9	90	180	127	553	592	772	225
150	10	7460	17,2	90	180	140	619	658	838	225
200	10	13300	38,1	100	215	170	809	862	1100	325
250	10	20800	59,7	114	215	198	907	960	1300	325
300	10	30000	86,1	114	215	223	1033	1090	1425	380
350	10	40720	159	127	290	260	1166	1265	1695	450
400	10	53310	208	140	290	290	1372	--	--	--
450	10	67450	264	152	290	308	1472	--	--	--
500	10	83470	375	152	290	335	1670	--	--	--
600	10	120440	666	178	290	390	1825	--	--	--
700	10	163530	903	229	380	448	2210	--	--	--
800	6	129210	718	241	340	508	2490	--	--	--
900	6	163440	908	241	340	558	2690	--	--	--
1000	6	202220	1335	300	350	615	2920	--	--	--
1200	6	291440	2228	350	520	728	3630	--	--	--

table 4

C.M.O.

Amategui Aldea 142, 20400 Txarama-Tolosa (SPAIN)

TEC-D.EN04

Tel. Nacional: 902.40.80.50 Fax: 902.40.80.51 / Tel. Internacional: 34.943.67.33.99 Fax: 34.943.67.24.40

cmo@cmo.es <http://www.cmo.es>

Page 10

GATE VALVES

D SERIES

HANDWHEEL with non-rising stem

- Suitable when no size limitations exist.
- **B = Max. width** of the valve (without actuator)
D = Max. height of the valve (without actuator).
- Options:
 - Square nut.
 - Locking devices.
 - Extensions: stand, pipe, plates,...
 - DN higher than those shown in the table.
- Actuator including:
 - Handwheel.
 - Stem.
 - Guide bushing on the yoke.
 - Nut.
- Available: DN50 to DN2000, other DN to order.
- From DN350 the actuator is with geared motor.

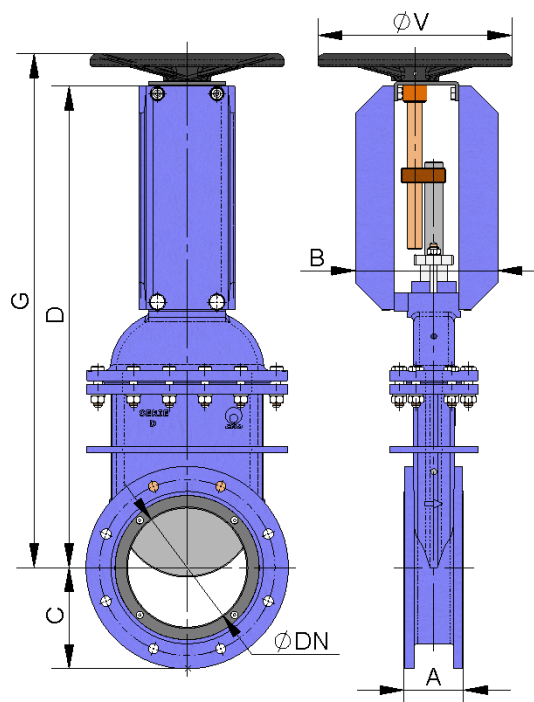

fig. 15

DN	ΔP (Kg/cm ²)	DRAW (Nw)	TORQUE (Nm)	A	B	C	D	G	ϕV
50	10	830	1,91	70	124	83	375	415	225
65	10	1400	3,22	70	124	93	408	448	225
80	10	2120	4,9	70	124	100	443	483	225
100	10	3320	7,61	70	151	110	489	529	225
125	10	5180	11,9	90	166	127	588	628	225
150	10	7460	17,2	90	166	140	654	694	225
200	10	13300	38,1	100	203	170	809	862	325
250	10	20800	59,7	114	203	198	922	975	325
300	10	30000	86,1	114	203	223	1048	1101	380
350	10	40720	159	127	350	260	1253	1352	450
400	10	53310	208	140	350	290	1444	--	--
450	10	67450	264	152	350	308	1642	--	--
500	10	83470	375	152	350	335	1755	--	--
600	10	120440	666	178	350	390	1910	--	--
700	10	163530	903	229	390	448	2305	--	--
800	6	129210	718	241	390	508	2585	--	--
900	6	163440	908	241	390	558	2775	--	--
1000	6	202220	1335	300	400	615	3020	--	--
1200	6	291440	2228	350	420	728	3750	--	--

table 5

C.M.O.

Amategui Aldea 142, 20400 Txarama-Tolosa (SPAIN)

TEC-D.EN04

Tel. Nacional: 902.40.80.50 Fax: 902.40.80.51 / Tel. Internacional: 34.943.67.33.99 Fax: 34.943.67.24.40

cmo@cmo.es <http://www.cmo.es>

Page 11

GATE VALVES

D SERIES

CHAINWHEEL

- Widely used in raised installations with difficult access, the handwheel is fitted in vertical position.
- **B = Max. width** of the valve (without actuator)
D = Max. height of the valve (without actuator).
- Options:
 - Locking devices.
 - Extensions: stand, pipe, plates,...
 - Non-rising stem.
 - DN higher than those shown in the table.
- Including:
 - Handwheel.
 - Stem.
 - Nut.
 - Hood.
- Available: DN50 to DN2000, other DN to order.
- From DN350 the actuator is with geared motor, see * in table.

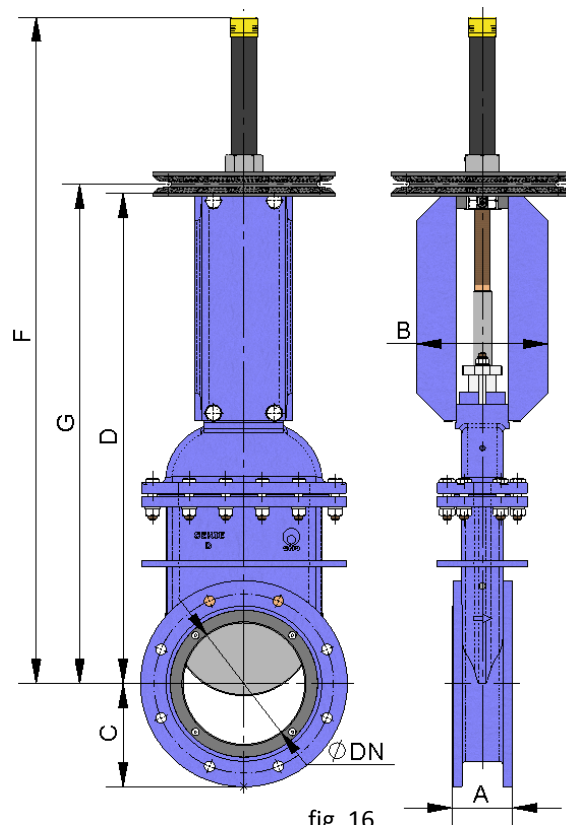

fig. 16

DN	ΔP (Kg/cm ²)	DRAW (Nw)	TORQUE (Nm)	A	B	C	D	G	F	ØV
50	10	830	1,91	70	106	83	330	369	498	225
65	10	1400	3,22	70	106	93	365	404	534	225
80	10	2120	4,9	70	106	100	401	440	570	225
100	10	3320	7,61	70	160	110	468	507	637	225
125	10	5180	11,9	90	180	127	553	592	772	225
150	10	7460	17,2	90	180	140	619	658	838	225
200	10	13300	38,1	100	215	170	809	862	1100	300
250	10	20800	59,7	114	215	198	907	960	1300	300
300	10	30000	86,1	114	215	223	1033	1090	1425	300
350	10	40720	159	127	290	260	1166	1265	1695	402
400	10	53310	208	140	290	290	1372	1482	1905	402*
450	10	67450	264	152	290	308	1472	1566	2160	402*
500	10	83470	375	152	290	335	1575	1669	2263	402*
600	10	120440	666	178	290	390	1825	1919	2613	402*
700	10	163530	903	229	380	448	2089	2221	2930	402*
800	6	129210	718	241	340	508	2380	2512	3410	402*
900	6	163440	908	241	340	558	2690	2898	3895	402*
1000	6	202220	1335	300	350	615	2920	3015	4052	402*
1200	6	291440	2228	350	520	728	3630	3835	5120	402*

table 6

C.M.O.

Amategui Aldea 142, 20400 Txarama-Tolosa (SPAIN)

TEC-D.EN04

Tel. Nacional: 902.40.80.50 Fax: 902.40.80.51 / Tel. Internacional: 34.943.67.33.99 Fax: 34.943.67.24.40

cmo@cmo.es <http://www.cmo.es>

Page 12



GATE VALVES

D SERIES

LEVER

- This is a fast actuator.
- **B = Max. width** of the valve (without actuator)
- **D = Max. height** of the valve (without actuator).
- The actuator includes:
 - Lever.
 - Stem.
 - Guide bushing.
 - External blockers to maintain position.
- Available: DN50 to DN200, other DN to order.

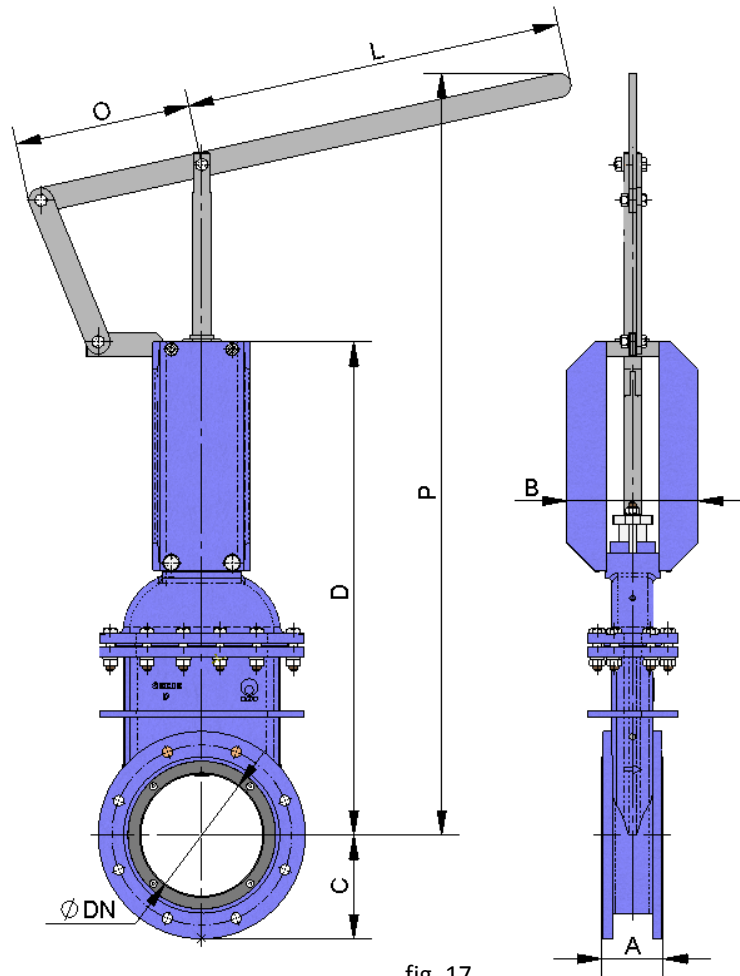

fig. 17

DN	ΔP (Kg/cm ²)	DRAW (Nw)	A	B	C	D	L	O	P
50	10	830	70	106	83	330	325	155	598
65	10	1400	70	106	93	365	325	155	633
80	10	2120	70	106	100	401	325	155	669
100	10	3320	70	160	110	468	325	155	736
125	10	5180	90	180	127	553	425	155	1082
150	10	7460	90	180	140	619	425	155	1148
200	10	13300	100	215	170	809	620	290	1324

table 7



GATE VALVES

D SERIES

GEAR BOX

- It is recommendable for DN greater than 350.
- **B = Max. width** of the valve (without actuator)
D = Max. height of the valve (without actuator).
- Options:
 - Chainwheel.
 - Locking devices.
 - Extensions: stand, pipe, plates,...
 - Non-rising stem.
- Actuator comprising:
 - Stem.
 - Yoke.
 - Cone-shaped gear box.
 - Handwheel.
- Standard reduction ratio = 4 to 1.
- Available: DN 50 to DN 2000, other DN to order.

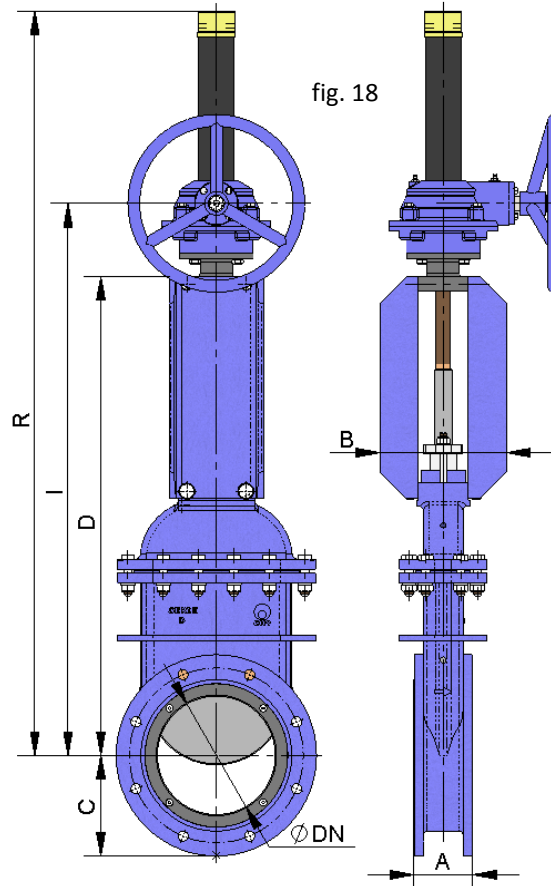

DN	ΔP (Kg/cm ²)	DRAW (Nw)	TORQUE (Nm)	A	B	C	D	I	R
50	10	830	1,91	70	106	83	330	451	601
65	10	1400	3,22	70	106	93	365	487	661
80	10	2120	4,9	70	106	100	401	523	697
100	10	3320	7,61	70	160	110	456	578	752
125	10	5180	11,9	90	180	127	528	650	824
150	10	7460	17,2	90	180	140	619	743	917
200	10	13300	38,1	100	215	170	809	933	1227
250	10	20800	59,7	114	215	198	907	1030	1324
300	10	30000	86,1	114	215	223	1033	1156	1450
350	10	40720	159	127	290	260	1156	1250	1694
400	10	53310	208	140	290	290	1372	1482	1905
450	10	67450	264	152	290	308	1472	1566	2160
500	10	83470	375	152	290	335	1575	1669	2263
600	10	120440	666	178	290	390	1825	1919	2613
700	10	163530	903	229	380	448	2089	2221	2930
800	6	129210	718	241	340	508	2380	2512	3410
900	6	163440	908	241	340	558	2690	2898	3895
1000	6	202220	1335	300	350	615	2920	3015	4052
1200	6	291440	2228	350	520	728	3630	3835	5120

table 8

C.M.O.

Amategui Aldea 142, 20400 Txarama-Tolosa (SPAIN)

TEC-D.EN04

Tel. Nacional: 902.40.80.50 Fax: 902.40.80.51 / Tel. Internacional: 34.943.67.33.99 Fax: 34.943.67.24.40

cmo@cmo.es <http://www.cmo.es>

Page 14

GATE VALVES

D SERIES

DOUBLE-ACTING PNEUMATIC CYLINDER

- The air supply pressure to the pneumatic cylinder is a minimum of 6 Kg/cm² and a maximum of 10 Kg/cm², the air must be dry and lubricated.
- 10 Kg/cm² is the maximum admissible air pressure. For air pressures below 6 Kg/cm², please check with CMO.
- For DN50 to DN200 valves, the cylinder's jacket and covers are made of aluminium, the spindle of AISI304, the piston of rubber-coated steel and the O-ring seals are made of nitrile.
- For valves larger than DN200 the covers are made of nodular cast iron or carbon steel.

To order, we can also supply the actuator made entirely of stainless steel, especially for installation in corrosive atmospheres.

- **B = Max. width** of the valve (without actuator)
- **D = Max. height** of the valve (without actuator).

- Available: DN50 to DN900, other DN to order.

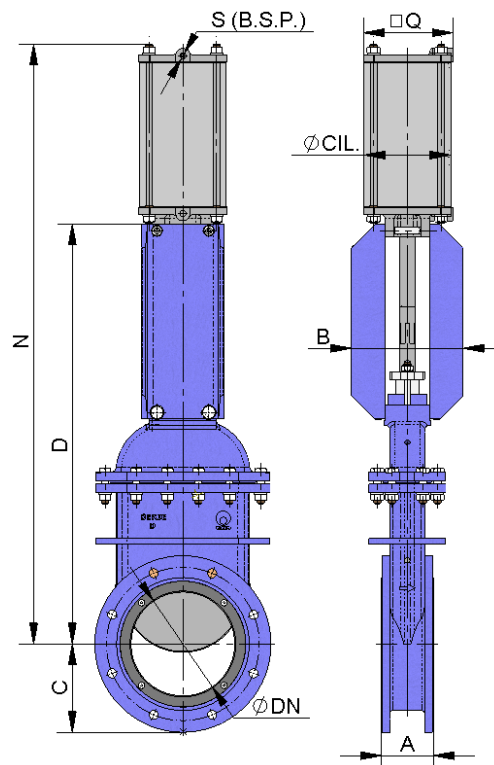

fig. 19

DN	ΔP (Kg/cm ²)	DRAW (Nw)	A	B	C	D	N	Q	Ø CYL.	Ø STEM	S (B.S.P.)
50	10	830	70	106	83	347	535	90	80	20	1/4"
65	10	1400	70	106	93	381	582	90	80	20	1/4"
80	10	2120	70	106	100	426	650	90	80	20	1/4"
100	10	3320	70	160	110	468	720	110	100	20	1/4"
125	10	5180	90	180	127	553	824	135	125	25	1/4"
150	10	7460	90	180	140	649	949	170	160	30	1/4"
200	10	13300	100	215	170	809	1167	215	200	30	3/8"
250	10	20800	114	215	198	913	1418	270	250	40	3/8"
300	10	30000	114	215	223	1033	1603	382	300	45	1/2"
350	10	40720	127	290	260	1156	1774	444	350	45	1/2"
400	10	53310	140	290	290	1372	2083	508	400	50	1/2"
450	*	*	152	290	308	1442	2184	508	400	50	1/2"
500	*	*	152	290	335	1575	2410	508	400	50	1/2"
600	*	*	178	290	390	1825	2759	508	400	50	1/2"
700	*	*	229	380	448	2089	3144	508	400	50	1/2"
800	*	*	241	340	508	2438	3574	508	400	50	1/2"
900	*	*	241	340	558	2692	3944	508	400	50	1/2"

* → Consult

table 9

C.M.O.

Amategui Aldea 142, 20400 Txarama-Tolosa (SPAIN)

TEC-D.EN04

Tel. Nacional: 902.40.80.50 Fax: 902.40.80.51 / Tel. Internacional: 34.943.67.33.99 Fax: 34.943.67.24.40

cmo@cmo.es <http://www.cmo.es>

Page 15

GATE VALVES

D SERIES

SINGLE-ACTING PNEUMATIC CYLINDER

- The air supply pressure to the pneumatic cylinder is a minimum of 6 Kg/cm² and a maximum of 10 Kg/cm², the air must be dry and lubricated.
- 10 Kg/cm² is the maximum admissible air pressure. For air pressures below 6 Kg/cm², please check with the manufacturer.
- Available for opening or closing in the event of air supply failure (spring opens or closes).
- The casing is made of aluminium, the covers of nodular cast iron or carbon steel, the spindle of AISI304, the piston of rubber-coated steel, the O-ring seals of nitrile and the spring is made of steel.
- The **actuator design is spring activated** for valves with diameters **up to DN200**. For larger diameters the actuator contains a double-acting cylinder and an air tank which stores the volume of air necessary to perform the last movement in the event of an air supply failure.
- **B = Max. width** of the valve (without actuator)
D = Max. height of the valve (without actuator).
- Available: DN50 to DN200, other DN to order.
- Please see the "CMO Pneumatic Actuators" catalogue if you require further information.

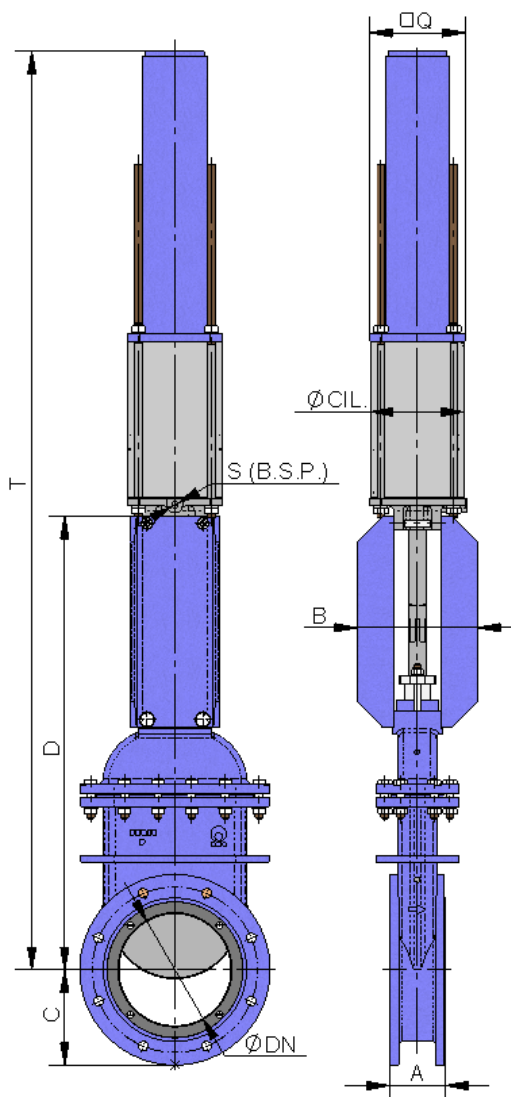

fig. 20

DN	ΔP (Kg/cm ²)	DRAW (Nw)	A	B	C	D	Q	T	ϕ CYL.	ϕ STEM	S (B.S.P.)
50	10	830	70	106	83	347	135	887	125	25	1/4"
65	10	1400	70	106	93	381	135	919	125	25	1/4"
80	10	2120	70	106	100	426	135	965	125	25	1/4"
100	10	3320	70	160	110	468	135	1007	125	25	1/4"
125	10	5180	90	180	127	553	170	1096	160	30	1/4"
150	10	7460	90	180	140	649	215	1495	200	30	3/8"
200	10	13300	100	215	170	809	270	2084	250	40	3/8"

table 10

C.M.O.

Amategui Aldea 142, 20400 Txarama-Tolosa (SPAIN)

TEC-D.EN04

Tel. Nacional: 902.40.80.50 Fax: 902.40.80.51 / Tel. Internacional: 34.943.67.33.99 Fax: 34.943.67.24.40

cmo@cmo.es <http://www.cmo.es>

Page 16

GATE VALVES

D SERIES

ELECTRIC ACTUATOR

- This actuator is automatic and includes the following parts:
 - Electric motor.
 - Stem.
 - Yoke.
- The electric motor includes:
 - Emergency manual handwheel.
 - Limit switches.
 - Torque limiters.
- Options:
 - Different types and brands.
 - Non-rising stem.
- ISO 5210 / DIN 3338 Flanges.
- Available: DN50 to DN2000, other DN to order.
- From DN300 the motor is assisted with a gear box.

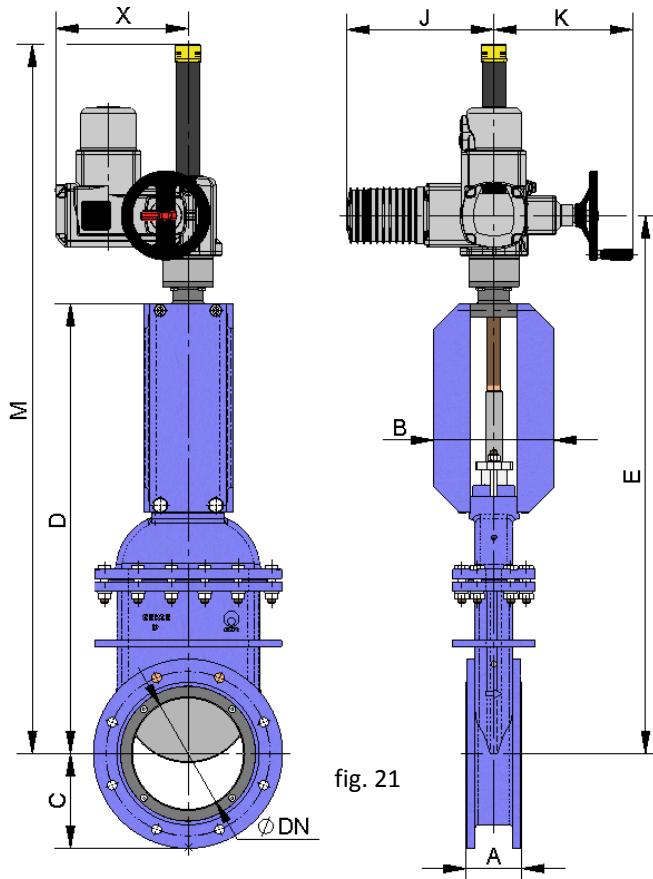

DN	ΔP (Kg/cm ²)	DRAW (Nw)	TORQUE (Nm)	A	B	C	D	E	J	K	M	X
50	10	830	1,91	70	106	83	330	489	265	250	642	238
65	10	1400	3,22	70	106	93	365	523	265	250	702	238
80	10	2120	4,9	70	106	100	401	559	265	250	737	238
100	10	3320	7,61	70	160	110	456	614	265	250	792	238
125	10	5180	11,9	90	180	127	528	686	265	250	864	238
150	10	7460	17,2	90	180	140	619	777	265	250	957	238
200	10	13300	38,1	100	215	170	809	967	265	250	1273	238
250	10	20800	59,7	114	215	198	907	1055	265	250	1370	238
300	10	30000	86,1	114	215	223	1033	1181	283	255	1446	248
350	10	40720	159	127	290	260	1156	1290	265	250	1694	422
400	10	53310	208	140	290	290	1372	1506	265	250	1905	422
450	10	67450	264	152	290	308	1472	1606	265	250	2160	422
500	10	83470	375	152	290	335	1575	1719	283	255	2263	424
600	10	120440	666	178	290	390	1825	1988	283	255	2613	479
700	10	163530	903	229	380	448	2089	2291	283	255	2930	479
800	6	129210	718	241	340	508	2380	2615	283	255	3410	479
900	6	163440	908	241	340	558	2690	2902	283	255	3895	479
1000	6	202220	1335	300	350	615	2920	3160	389	335	4052	605
1200	6	291440	2228	350	520	728	3630	3896	389	335	5120	605

table 11

C.M.O.

Amategui Aldea 142, 20400 Txarama-Tolosa (SPAIN)

TEC-D.EN04

Tel. Nacional: 902.40.80.50 Fax: 902.40.80.51 / Tel. Internacional: 34.943.67.33.99 Fax: 34.943.67.24.40

cmo@cmo.es <http://www.cmo.es>

Page 17



GATE VALVES

D SERIES

HYDRAULIC ACTUATOR (Oil pressure: 135 Kg/cm²)

- **B = Max. width** of the valve (without actuator)
- **D = Max. height** of the valve (without actuator).

- The hydraulic actuator includes:
 - Hydraulic cylinder.
 - Yoke.

- Available: DN50 to DN2000.

- Different types and brands available according to customer's requirements.

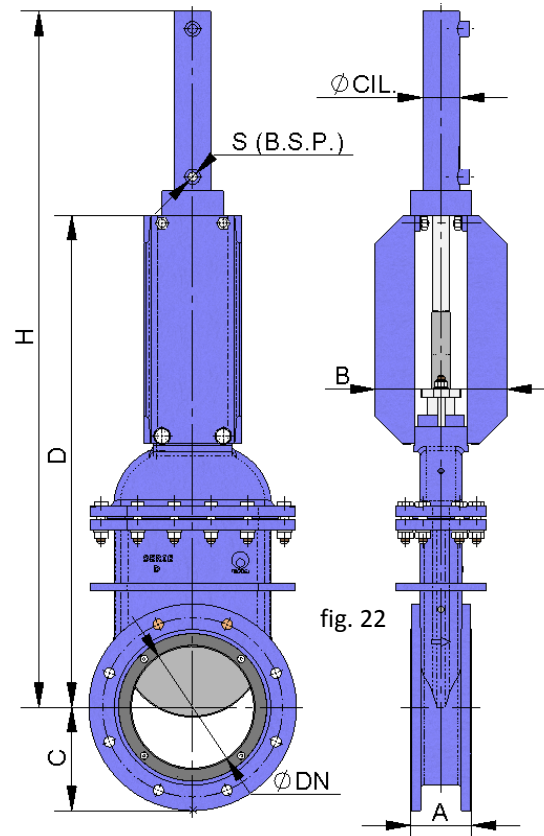

DN	ΔP (Kg/cm ²)	DRAW (Nw)	A	B	C	D	H	Ø CYL.	Ø STEM	S (B.S.P.)	Cap. Oil (dm ³)
50	10	830	70	106	83	330	546	25	18	3/8"	0.03
65	10	1400	70	106	93	365	597	25	18	3/8"	0.04
80	10	2120	70	106	100	401	667	25	18	3/8"	0.04
100	10	3320	70	160	110	456	742	32	22	3/8"	0.09
125	10	5180	90	180	127	528	844	32	22	3/8"	0.11
150	10	7460	90	180	140	619	955	40	28	3/8"	0.2
200	10	13300	100	215	170	809	1210	50	28	3/8"	0.42
250	10	20800	114	215	198	907	1358	63	36	3/8"	0.81
300	10	30000	114	215	223	1033	1553	80	45	3/8"	1.56
350	10	40720	127	290	260	1156	1735	100	56	1/2"	2.87
400	10	53310	140	290	290	1372	2000	100	56	1/2"	3.26
450	10	67450	152	290	308	1472	2190	125	70	1/2"	5.71
500	10	83470	152	290	335	1575	2343	125	70	1/2"	6.32
600	10	120440	178	290	390	1825	2720	160	70	1/2"	12.37
700	10	163530	229	380	448	2089	3108	160	70	1/2"	14.38
800	6	129210	241	340	508	2380	3478	160	70	1/2"	16.39
900	6	163440	241	340	558	2690	3930	160	70	1/2"	18.75
1000	6	202220	300	350	615	2920	4220	200	90	1/2"	32.36
1200	6	291440	350	520	728	3630	5175	200	90	1/2"	38.17

table 12

C.M.O.

Amategui Aldea 142, 20400 Txarama-Tolosa (SPAIN)

TEC-D.EN04

Tel. Nacional: 902.40.80.50 Fax: 902.40.80.51 / Tel. Internacional: 34.943.67.33.99 Fax: 34.943.67.24.40

cmo@cmo.es <http://www.cmo.es>

Page 18

GATE VALVES

D SERIES

INFORMATION ON FLANGE DIMENSIONS

EN 1092-2 PN10

DN	ΔP (Kg/cm ²)	Qty.	Metric	P	ØK
		●			
50	10	4	M 16	12	125
65	10	4	M 16	12	145
80	10	8	M 16	12	160
100	10	8	M 16	12	180
125	10	8	M 16	16	210
150	10	8	M 20	16	240
200	10	8	M 20	16	295
250	10	12	M 20	20	350
300	10	12	M 20	18	400
350	10	16	M 20	19	460
400	10	16	M 24	22	515
450	10	20	M 24	24	565
500	10	20	M 24	24	620
600	10	20	M 27	30	725
700	10	24	M 27	35	840
800	6	24	M 30	35	950
900	6	28	M 30	35	1050
1000	6	28	M 33	40	1160
1200	6	32	M 36	40	1380

table 13

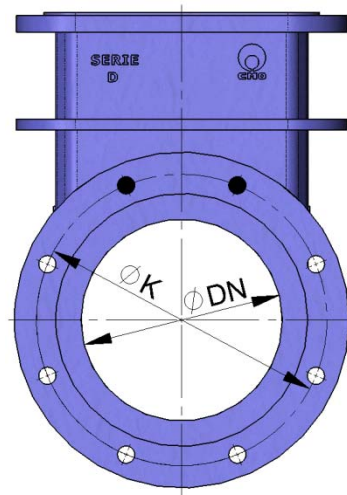

fig. 23

● BLIND HOLE

ANSI B16, class 150

ND	ΔP (Kg/cm ²)	Qty.	R UNC	P	ØK
		●			
2"	10	4	5/8"	10	120,6
2 ½"	10	4	5/8"	10	139,7
3"	10	4	5/8"	12	152,4
4"	10	8	5/8"	12	190,5
5"	10	8	3/4"	12	215,9
6"	10	8	3/4"	17	241,3
8"	10	8	3/4"	16	298,4
10"	10	12	7/8"	19	361,9
12"	10	12	7/8"	19	431,8
14"	10	12	1"	28	476,2
16"	10	16	1"	28	539,7
18"	10	16	1 ¼"	28	577,8
20"	10	20	1 ¼"	34	635
24"	10	20	1 ¼"	26	749,3
28"	10	28	1 ¼"	25	863,6
32"	6	28	1 ½"	21	977,9
36"	6	32	1 ½"	21	1085,9
40"	6	36	1 ½"	30	1200,2
48"	6	44	1 ½"	30	1422,4

table 14

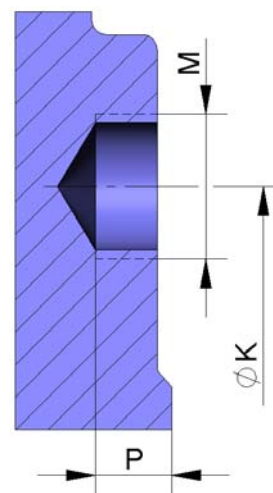

fig. 24

C.M.O.

Amategui Aldea 142, 20400 Txarama-Tolosa (SPAIN)

TEC-D.EN04

Tel. Nacional: 902.40.80.50 Fax: 902.40.80.51 / Tel. Internacional: 34.943.67.33.99 Fax: 34.943.67.24.40

cmo@cmo.es <http://www.cmo.es>

Page 19