

UNIDIRECTIONAL WAFER Knife Gate Valve

- Unidirectional wafer-design knife gate valve.
- One-piece cast body with guides to support gate and seat wedges.
- Provides high flow rates with low pressure drop.
- Various seat and packing materials available.
- Face-to-face dimension in accordance with CMO standard.
- An arrow is marked on the body indicating the flow direction.

General Applications:

-This knife gate valve is suitable for liquids that contain a maximum of 5% suspended solids. If it is used for dry solids in gravity feed applications it should be installed with the arrow on the body pointing in the opposite direction to the flow. Designed for applications such as:

- Paper Industry
- Mining
- Silo emptying
- Chemical plants
- Pumping
- Food Industry
- Sewage treatment

Sizes: ND50 to ND2000 (larger sizes on request).

Working Pressure: -ND50 to ND150: 10kg/cm² -ND200: 8kg/cm²
 -ND250 to ND300: 6kg/cm² -ND350 to ND400: 5kg/cm²
 -ND450 to ND600: 3kg/cm² -ND700 to ND1400: 2kg/cm²

- The mentioned working pressures are just valid for the pressures applied on the direction of the arrow market on the body. As the valve is designed with gate support guides, the valves are able to support a 30% of these pressures from the opposite direction without any damage on them. In these cases, the valves are not 100% water tight. To obtain total water tightness in these conditions, it is necessary to incorporate additional supports.

Standard Flanges: DIN PN10 and ANSI B16.5 (class 150)

Other Common Flanges: DIN PN 6 DIN PN 16 DIN PN25
 BS "D" and "E" ANSI 150 Others on request

Directives: Machinery Directive: **DIR 2006/42/EC (MACHINERY)**
 Pressure Equipment Directive: **DIR 97/23/EC (PED) ART.3, P.3**
 Potential Explosive Atmospheres Directive: **DIR 94/9/EC (ATEX) CAT.3 ZONE 2 and 22 GD**
 For further information on categories and zones please contact the CMO Technical-Commercial Dept.

Quality Dossier:

- All valves are tested hydrostatically at CMO and material and test certificates can be provided.
- Body test = working pressure x 1.5.
- Seat test = working pressure x 1.1.

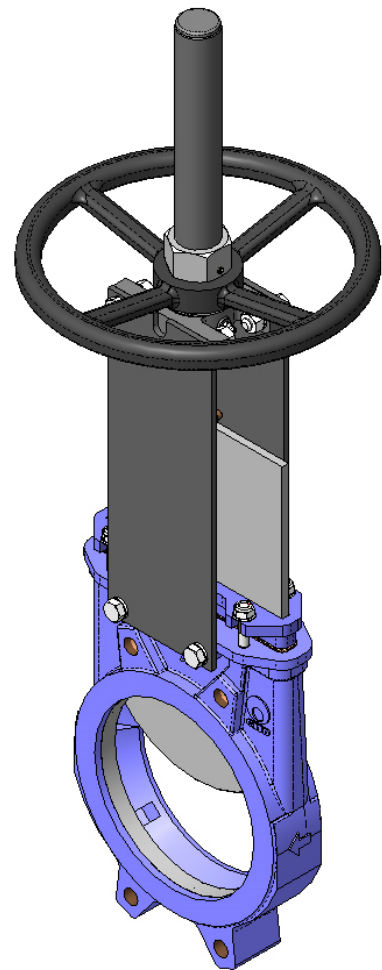

fig. 1

KNIFE-GATE VALVES

A SERIES

Advantages of CMO's "Model A" compared to similar products

When a knife gate valve remains open for long periods of time and the body's internal walls are parallel a very large torque is required to close it. Model A's body is cone-shaped inside, providing greater space. This way, when the valve is closed the solids stored inside it can be easily removed.

This valve is defined as unidirectional and these valves are normally at risk of the gate bending due to counter-pressure. This cannot happen with the CMO valve because it contains internal guides that support the knife gate and allow it to work under counter-pressure of 30% of the maximum working pressure, without the knife gate bending.

The stem protection hood is independent from the handwheel securing nut, this means the hood can be disassembled without the need to release the handwheel. This advantage allows regular maintenance operations to be performed, such as lubricating the stem, etc.

The stem on the CMO valve is made of 18/8 stainless steel. This is another added advantage, as some manufacturers produce it with 13% chrome and it gets rusty very quickly.

The handwheel is made of GJS-500 nodular cast iron. Some manufacturers produce them in normal cast iron which can lead to breakages in the event of very high operating torque or knocks.

The yoke is has a compact design with the bronze actuator nut protected in a sealed and lubricated box. This makes it possible to move the valve with a key, even without the handwheel (in other manufacturers' products this is not possible).

The pneumatic actuator's upper and lower covers are made of GJS-400 nodular cast iron, making them highly shock resistant.

This characteristic is essential in pneumatic actuators.

The pneumatic cylinder's o-ring seals are commercial products and can be purchased worldwide. This means it is not necessary to contact CMO every time a seal is required.

STANDARD COMPONENTS LIST		
COMPONENT	CAST IRON VERSION	ST. STEEL VERSION
1- Body	GJL-250	CF8M
2- Gate	AISI304	AISI316
3- Guide	RCH1000	
4- Packing gland	GJS-500	CF8M
5- Packing	SYNT + PTFE	
6- O-ring seal	EPDM	
7- Support plates	S275JR	
8- Ring	AISI316	
9- Seat	EPDM	
10- Stem	AISI303	
11- Yoke	STEEL	
12- Stem nut	BRONZE	
13- Check nut	ST44.2 + ZINC	
14- Handwheel	NODULAR CAST IRON	
15- Nut	STEEL	
16- Hood	STEEL	
17- Top cap	PLASTIC	

table 1

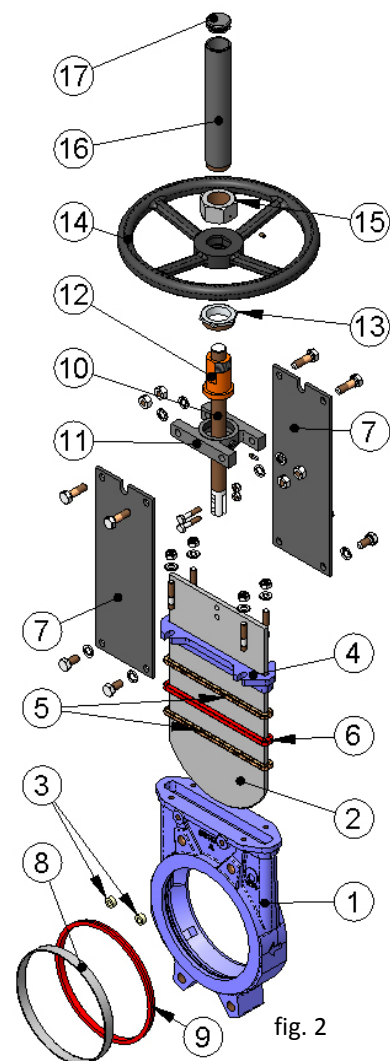

fig. 2

C.M.O.

Amategui Aldea 142, 20400 Txarama-Tolosa (SPAIN)

TEC-A.EN07

Tel. Nacional: 902.40.80.50 Fax: 902.40.80.51 / Tel. Internacional: 34.943.67.33.99 Fax: 34.943.67.24.40

cmo@cmo.es <http://www.cmo.es>

Page 2

DESIGN CHARACTERISTICS

1- BODY

Unidirectional wafer-design knife gate valve. One-piece cast body with guides to support gate and seat wedges.

For diameters greater than ND1200 the body is machine-welded with the necessary reinforcements to resist the maximum working pressure.

Full port designed to provide high flow rates with low pressure drop.

The body's internal design prevents any build up of solids in the seat area.

The standard manufacturing materials are GJL-250 cast iron and CF8M stainless steel. Other materials, such as GJS-500 nodular cast iron, A216WCB carbon steel and stainless steel alloys (AISI316Ti, Duplex, 254SMO, Uranus B6...) are available on request. As standard, iron or carbon steel valves are painted with an anti-corrosive protection of 80 microns of EPOXY (colour RAL 5015). Other types of anti-corrosive protections are available on request.

2- GATE

The standard manufacturing materials are AISI304 stainless steel in valves with iron body and AISI316 stainless steel in valves with CF8M body. Other materials or combinations can be supplied on request.

The gate is polished on both sides to provide a smooth contact surface with the resilient seat. At the same time, the gate is rounded to prevent the seat from being cut. Different degrees of polishing, anti-abrasion treatments and modifications are available to adapt the valves to the customer's requirements.

3- SEAT: (watertight)

Six types of seats are available according to the working application:

Seat 1: Metal / metal seat. This type of seat does not include any kind of resilient seat and the estimated leakage (considering water as the test fluid) is 1.5% of the pipe flow.

Seat 2: Standard soft-seated valve. This type of seat includes a resilient seat which is fixed to the inside of the body via an AISI316 stainless steel retaining ring.

Seat 3: Soft-seated valve with reinforced socket. This type of seat includes a resilient seat which is fixed to the inside of the body via an AISI316 stainless steel retaining ring with two functions (to protect the valve from abrasion and clean the gate when working with solids that can stick to it).

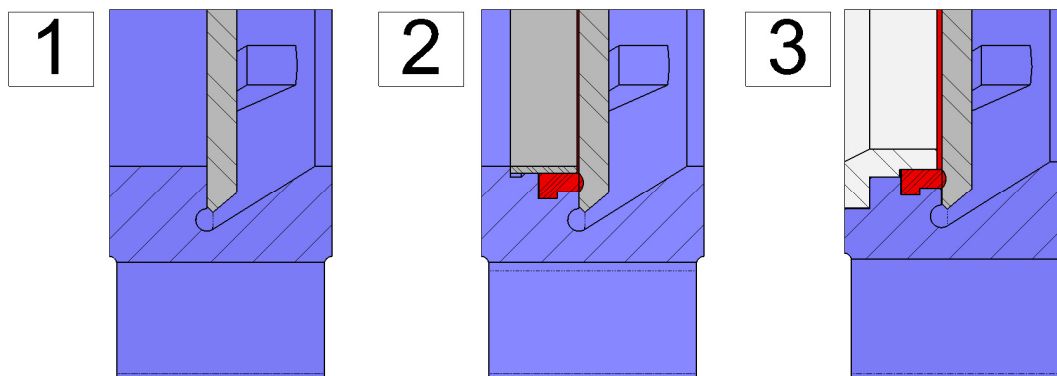

fig. 3

C.M.O.

Amategui Aldea 142, 20400 Txarama-Tolosa (SPAIN)

TEC-A.EN07

Tel. Nacional: 902.40.80.50 Fax: 902.40.80.51 / Tel. Internacional: 34.943.67.33.99 Fax: 34.943.67.24.40

cmo@cmo.es <http://www.cmo.es>

Page 3

KNIFE-GATE VALVES

A SERIES

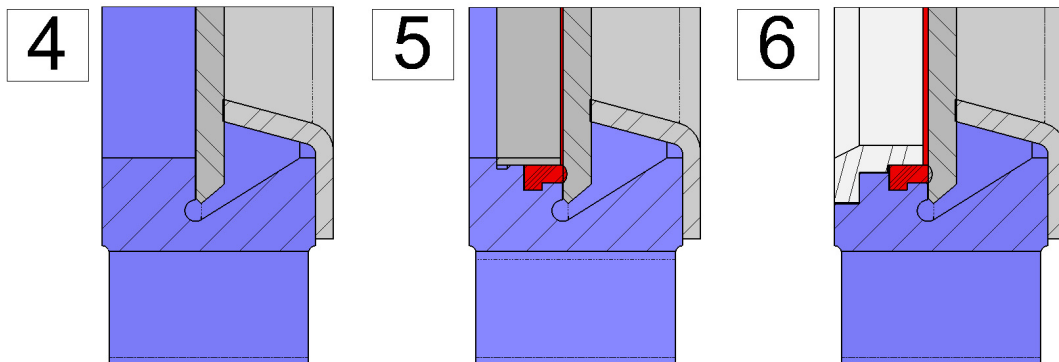



fig. 4

Seats 4, 5 and 6: The same as seats 1, 2 and 3 but including a deflector. The deflector is a cone-shaped ring located at the valve's entrance with two functions (to protect the valve from abrasion and guide the flow to the centre of the valve).

 **Note:** Three materials are available for the reinforced socket and the deflector (CA-15 steel, CF8M and Ni-hard).

Resilient seat materials

EPDM

This is the standard resilient seat fitted on CMO valves. It can be used in many applications, however, it is generally used for water and products diluted in water at temperatures no higher than 90°C*. It can also be used with abrasive products and it provides the valve with 100% watertight integrity.

NITRILE

It is used in fluids containing fats or oils at temperatures no higher than 90°C*. It provides the valve with 100% watertight integrity.

VITON

Suitable for corrosive applications and continuous high temperatures of up to 190°C and peaks of 210°C. It provides the valve with 100% watertight integrity.

SILICONE

Mainly used in the food industry and for pharmaceutical products with temperatures no higher than 200°C. It provides the valve with 100% watertight integrity.

PTFE

Suitable for corrosive applications and pH between 2 and 12. Does not provide the valve with 100% watertight integrity. Estimated leakage: 0.5% of the tube flow.

 **Note:** In some applications other types of resilient materials are used, such as hypalon, butile or natural rubber. Please contact us if you require one of these materials.

4- PACKING

CMO's standard packing is composed of three lines with a specially designed EPDM O-ring in the middle which provides watertight integrity between the body and the gate, preventing any type of leakage to the atmosphere. It is located in an easily accessible place and can be replaced without dismantling the valve from the pipeline. Below we indicate various types of packing available according to the application in which the valve is located:

C.M.O.

Amategui Aldea 142, 20400 Txarama-Tolosa (SPAIN)

TEC-A.EN07

Tel. Nacional: 902.40.80.50 Fax: 902.40.80.51 / Tel. Internacional: 34.943.67.33.99 Fax: 34.943.67.24.40

cmo@cmo.es <http://www.cmo.es>

Page 4

KNIFE-GATE VALVES

A SERIES

GREASED COTTON (Recommended for hydraulic services): This packing is composed of braided cotton fibres soaked in grease both inside and out. It is for general use in hydraulic applications in both pumps and valves.

DRY COTTON: This packing is composed of cotton fibres. It is for general use in hydraulic applications with solids.

COTTON + PTFE: This packing is composed of braided cotton fibres soaked in PTFE both inside and out. It is for general use in hydraulic applications in both pumps and valves.

SYNTHETIC + PTFE: This packing is composed of braided synthetic fibres soaked in PTFE both inside and out. It is for general use in hydraulic applications in both pumps and valves and in all types of fluids, especially corrosive ones, including concentrated and oxidising oils. It is also used in liquids with solid particles in suspension.

GRAPHITE: This packing is composed of high-purity graphite fibres. A diagonal braiding system is used and it is impregnated with graphite and lubricant which helps to reduce porosity and improve operation. It has a wide range of applications as graphite is resistant to steam, water, oils, solvents, alkali and most acids.

CERAMIC FIBRE: This packing is composed of ceramic material fibres. Its main applications are with air or gas at high temperatures and low pressures.

SEAT/SEALS			PACKING			
Material	Max. T. (°C)	Applications	Material	P(bar)	Max. T. (°C)	pH
Metal/Metal	>250	High temp./Low watertight integ.	Greased cotton	10	100	6-8
EPDM (E)	90 *	Non-mineral acids and oils	Dry cotton	0.5	100	6-8
Nitrile (N)	90 *	Hydrocarbons, oils and greases	Cotton + PTFE	30	120	6-8
Viton (N)	200	Hydrocarbons and solvents	Synthetic + PTFE	100	-200+270	0-14
Silicone (S)	200	Food Products	Graphite	40	650	0-14
PTFE (T)	250	Corrosion resistant	Ceramic Fibre	0.3	1400	0-14

NOTE: More details and other materials available on request.

* → EPDM and nitrile: is possible until serving temperature Max.: 120°C under request.

table 2

5- STEM

The stem on the CMO valve is made of 18/8 stainless steel. This characteristic provides high resistance and excellent corrosion-resistant properties.

The valve design can be rising stem or non-rising stem. When rising stem is required a stem hood is supplied to protect the stem from contact with dust and dirt, as well as keeping it lubricated.

6- PACKING GLAND

The packing gland allows uniform force and pressure to be applied to the packing to ensure watertight integrity.

As standard, valves with cast iron body include GJS-500 packing glands, whilst valves with stainless steel body have CF8M packing glands.

KNIFE-GATE VALVES

A SERIES

7- ACTUATORS

All types of actuators can be supplied, with the advantage that thanks to the **C.M.O.** design they are fully interchangeable. This design allows the customer to change the actuators themselves and no extra assembly accessories are required. A design characteristic of **C.M.O.** valves is that all actuators are interchangeable.

Manual:

- Handwheel with rising stem
- Handwheel with non-rising stem
- Chainwheel
- Lever
- Gear Box
- Others (square nut,...)

Automatic:

- Electric actuator
- Pneumatic cylinder
- Hydraulic cylinder

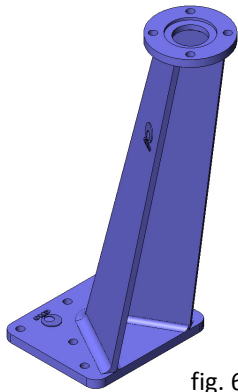

fig. 6

Wide Range of Accessories Available:

- Mechanical stops
- Locking devices
- Emergency manual actuators
- Solenoid valves
- Positioners
- Limit switches
- Proximity switches
- Straight floor stands (fig. 5)
- Leaning floor stand (fig. 6)
- ...

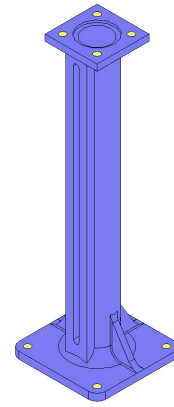

fig. 5

Stem extensions have also been developed, allowing the actuator to be located far away from the valve, to suit all needs. Please consult our technicians beforehand.

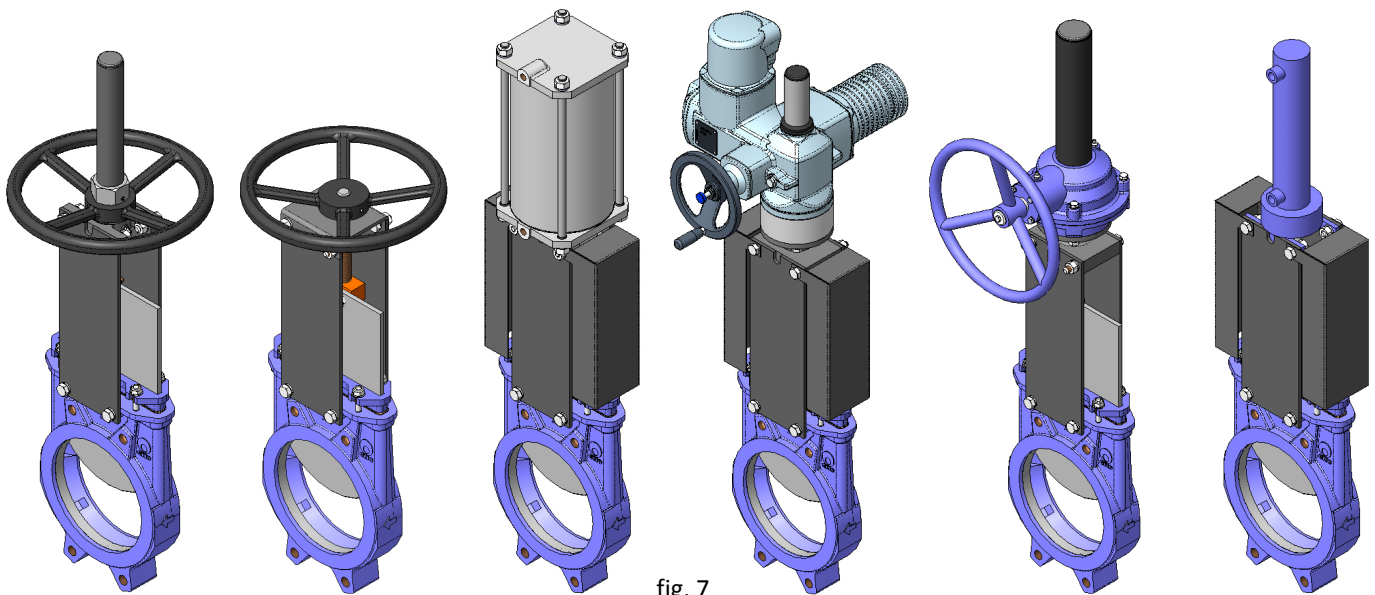

fig. 7

Handwheel rising stem

Handwheel NON-rising stem

Pneumatic actuator

Electric-motor actuator

Handwheel gear box

Hydraulic actuator

C.M.O.

Amategui Aldea 142, 20400 Txarama-Tolosa (SPAIN)

TEC-A.EN07

Tel. Nacional: 902.40.80.50 Fax: 902.40.80.51 / Tel. Internacional: 34.943.67.33.99 Fax: 34.943.67.24.40

cmo@cmo.es <http://www.cmo.es>

Page 6

KNIFE - GATE VALVES

A SERIES

ACCESSORIES AND OPTIONS

Different types of accessories are available to adapt the valve to specific working conditions such as:

- Mirror Polished Gate

The mirror polished gate is especially recommended in the food industry and, as standard, in applications in which solids can stick to the gate. It is an alternative to ensure the solids slide off and do not stick to the gate.

- PTFE Lined Gate

As with the mirror polished gate, it improves the valve's resistance to products that can stick to the gate.

- Stellite Gate

Stellite is added to the gate's lower edge to protect it from abrasion.

- Scraper in the Packing

Its function is to clean the gate during the opening movement and prevent possible damage to the packing.

- Air Injection in the Packing Gland

By injecting air in the packing, an air chamber is created which improves the watertight integrity.

- Heating Jacket

Recommended in applications in which the fluid can harden and solidify inside the valve's body. An external jacket keeps the body temperature constant, preventing the fluid from solidifying.

- Flushing Holes in Body (fig. 8)

Several holes can be drilled in the body to flush air, steam or other fluids out in order to clean the valve seat before sealing.

- Mechanical Limit Switches, Inductive Switches and Positioners

Limit switches or inductive switches are installed to indicate precise valve position, as well as positioners to indicate continuous position.

- Solenoid Valves

For air distribution to pneumatic actuators.

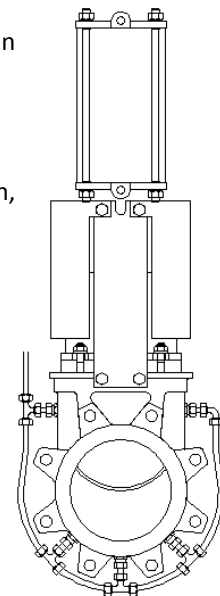

fig. 8



KNIFE-GATE VALVES

A SERIES

- Connection Boxes, Wiring and Pneumatic Piping

Fully assembled units can be supplied with all the necessary accessories.

- Stroke Limiting Mechanical Stops

They allow the stroke to be mechanically adjusted, limiting the valve's desired run.

- Mechanical Locking Device

Allows the valve to be mechanically locked in a set position for long periods of time.

- Emergency Manual Actuator (Hand Wheel /Gear Box)

Allows manual operation of the valve in the event of power or air failure.

- Triangular (V-Notch) and Pentagonal Diaphragm with Indication Rule (fig. 9)

Recommended for applications in which flow regulation is required.

Allows flow control according to the valve's opening percentage.

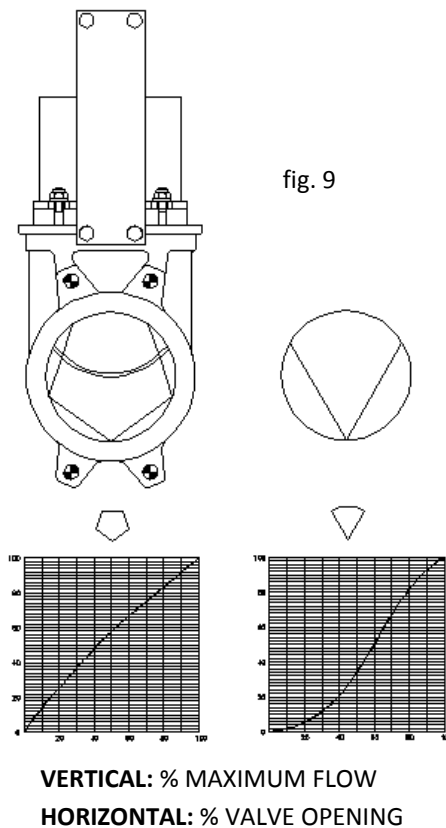

- Interchangeable Actuators

All actuators are easily interchangeable.

- Actuator or Yoke Support

Made of EPOXY-coated steel (or stainless steel on request), its robust design gives it great rigidity in order to resist the most adverse operation conditions.

- Epoxy Coating

All cast iron and carbon steel bodies and components on CMO valves are EPOXY coated, giving the valves great resistance to corrosion and an excellent finish.

CMO's standard colour is blue, RAL-5015.

- Gate Safety Protection

In accordance with European Safety Standards ("EC" marking), CMO automated valves are equipped with gate guards, to prevent any objects from being accidentally caught in the gate.

- Bonnet (fig. 10)

The bonnet provides total watertight integrity to the outside, reducing the packing maintenance required.

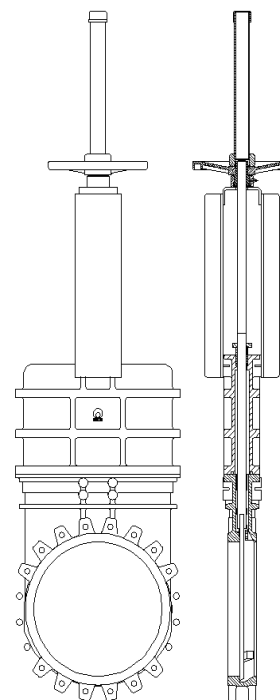

fig. 10

KNIFE-GATE VALVES

A SERIES

TYPES OF EXTENSION

When the valve needs to be operated from a distance, the following different types of actuators can be fitted:

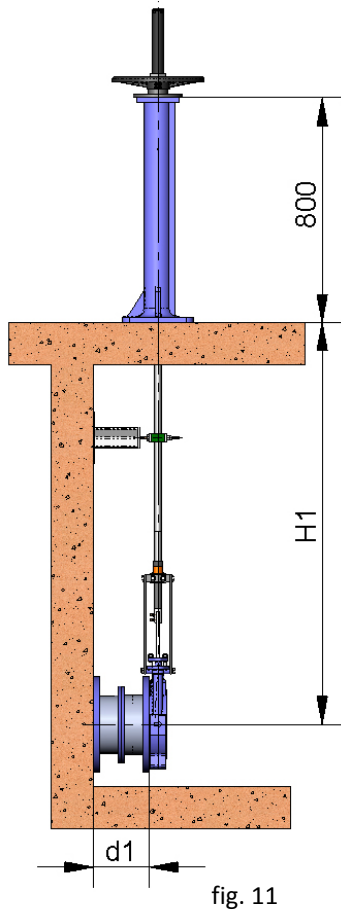

fig. 11

- Extension: Floor Stand.

This extension is achieved by coupling a rod to the stem. The desired extension length is achieved by defining the length of the rod. A floor stand is normally installed to support the actuator.

The definition variables are as follows:

H1: Distance from the valve's centre to the base of the stand.

d1: Separation from the wall to the end of the connecting flange.

Characteristics:

- It can be coupled to any type of actuator.
- A stem support-guide (Fig. 12) is recommended every 1.5 m.
- The standard floor stand is 800mm high (Fig. 11). Other floor stand measurements available on request:
- A position indicator can be fitted to determine the valve's percentage of opening.
- Tilting stand available on request (Fig. 13).

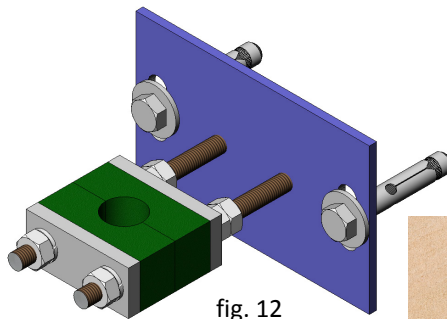

fig. 12

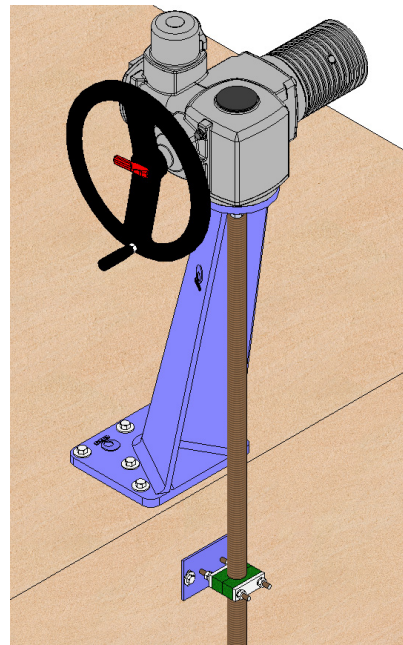

fig. 13

COMPONENTS LIST	
Component	Standard Version
Stem	AISI 303
Rod	AISI 304
Support-Guide	Carbon steel with EPOXY coating
Guide	Nylon
Stand	GJS-500 with EPOXY coating

table 3



KNIFE-GATE VALVES

A SERIES

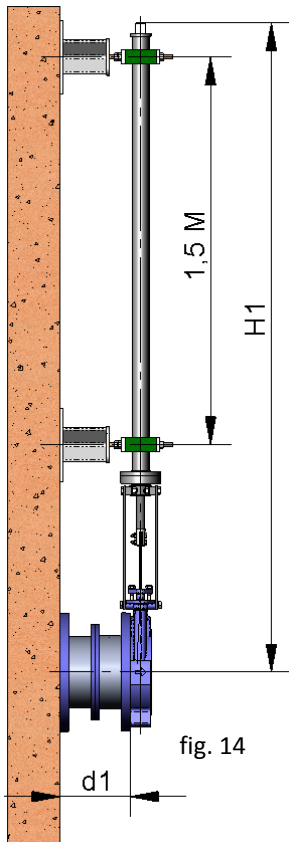

2 - Extension: Pipe (fig. 14)

Consists of raising the actuator. The pipe will rotate in the same direction as the handwheel when the valve is operated. The valve always remains at the same height.

The definition variables are as follows:

H1: Distance from the valve's centre to the base of the stand.

d1: Separation from the wall to the end of the connecting flange.

Characteristics:

- Standard actuators: Handwheel and "Square Nut"
- A pipe support-guide is recommended every 1.5m.
- The standard materials are: EPOXY coated carbon steel and stainless steel.

3 - Extension: Extended Support Plates (fig. 15)

When a short extension is required, it can be achieved by extending the support plates. An intermediate yoke can be fitted to reinforce the support plates' structure.

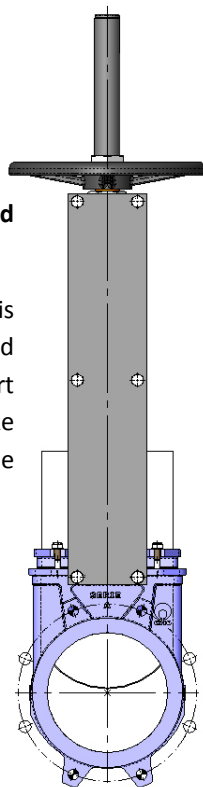

fig. 15

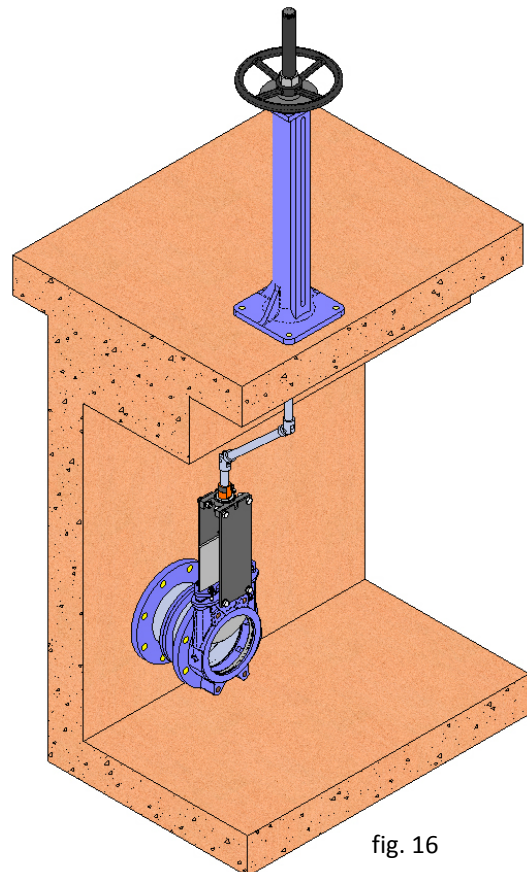

fig. 16

4 - Extension: Universal Joint (fig. 16)

If the valve and the actuator are not in correct alignment, the problem can be resolved by fitting a universal joint.

KNIFE-GATE VALVES

A SERIES

HANDWHEEL with Rising Stem

- **B = Max. width** of the valve (without actuator)
- **P = Max. height** of the valve (without actuator)
- Options:
 - Locking devices
 - Extensions: stand, pipe, plates...
 - ND higher than those give in the table
- Actuator including:
 - Handwheel
 - Stem
 - Nut
 - Stem protection hood
- Available: ND50 to ND 1200, other ND on request.
- From DN600 the actuator is with gears.

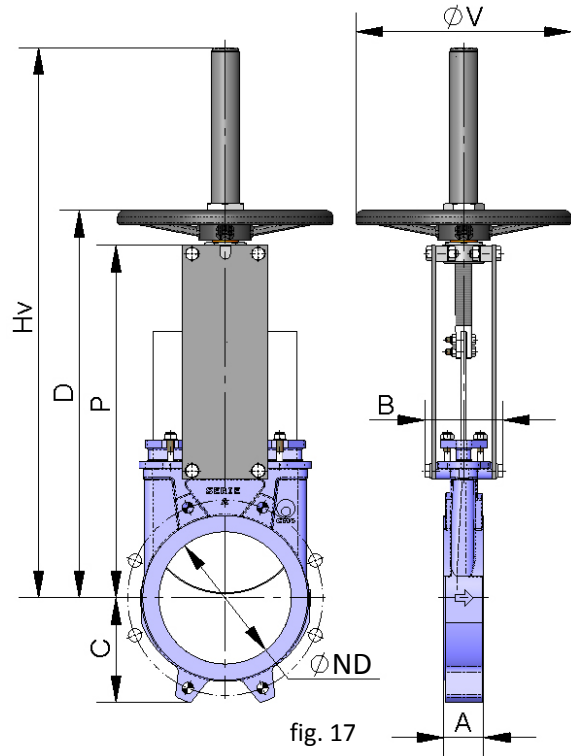

ND	ΔP (Kg/cm ²)	DRAW (Nw)	TORQ. (Nm)	A	B	C	P	Hv	D	ØV	Weight (kg.)
50	10	829	2	40	92	63	241	409	280	225	7
65	10	1399	3	40	92	70	268	436	307	225	8
80	10	2119	5	50	92	92	294	469	333	225	9
100	10	3310	8	50	92	105	334	502	373	225	11
125	10	5171	12	50	102	120	367	585	406	225	13
150	10	7448	17	60	102	130	419	644	458	225	17
200	8	10612	30	60	119	160	525	815	578	325	28
250	6	12456	36	70	119	198	626	1016	679	325	40
300	6	17962	51	70	119	234	726	1116	779	380	56
350	5	20406	79	96	290	256	797	1336	906	450	94
400	5	26707	104	100	290	292	903	1442	1012	450	116
450	3	20376	79	106	290	308	989	1628	1098	450	162
500	3	25230	98	110	290	340	1101	1738	1210	450	191
600	3	36506	142	110	290	400	1307	2046	1416	450	264
700	2	33288	182	110	320	453	1506	--	--	--	441
800	2	43788	239	110	320	503	1720	--	--	--	568
900	2	56064	307	110	320	583	1953	--	--	--	736
1000	2	69269	379	110	320	613	2137	--	--	--	921
1200	2	100819	654	150	340	728	2616	--	--	--	1350

table 4

C.M.O.

Amategui Aldea 142, 20400 Txarama-Tolosa (SPAIN)

TEC-A.EN07

Tel. Nacional: 902.40.80.50 Fax: 902.40.80.51 / Tel. Internacional: 34.943.67.33.99 Fax: 34.943.67.24.40

cmo@cmo.es <http://www.cmo.es>

Page 11

KNIFE-GATE VALVES

A SERIES

HANDWHEEL with Non-Rising Stem

- Suitable when no size limitations exist.
- **B = Max. width** of the valve (without actuator)
P = Max. height of the valve (without actuator)
- Options:
 - Square nut
 - Locking devices
 - Extensions: stand, pipe, plates...
 - DN higher than those give in the table
- Actuator including:
 - Handwheel
 - Stem
 - Guide bearings on the yoke.
 - Nut
- Available: ND50 to ND2000, other ND on request.
- From DN600 the actuator is with gears.

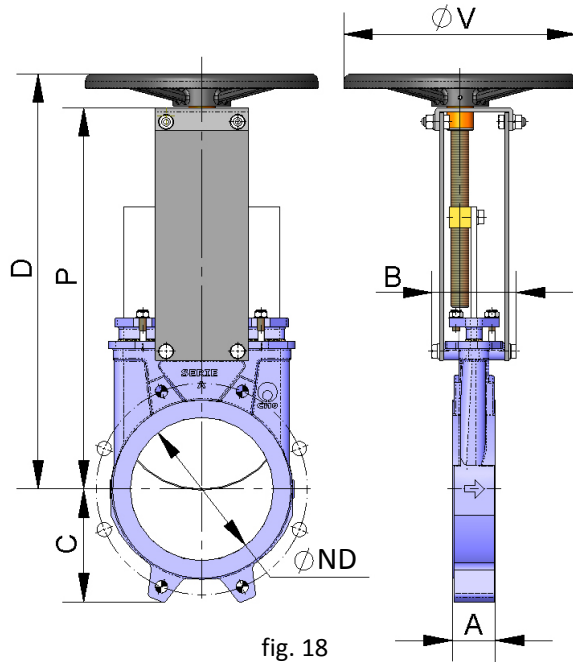

fig. 18

ND	ΔP (Kg/cm ²)	DRAW (Nw)	TORQUE (Nm)	A	B	C	P	D	ϕV	Weight (kg.)
50	10	829	2		101	63	241	280	225	7
65	10	1399	3	40	101	70	268	308	225	8
80	10	2119	5	50	101	92	294	333	225	9
100	10	3310	8	50	101	105	334	373	225	11
125	10	5171	12	50	111	120	367	407	225	13
150	10	7448	17	60	111	130	419	458	225	17
200	8	10612	30	60	128	160	525	578	325	29
250	6	12456	36	70	128	198	626	679	325	40
300	6	17962	51	70	128	234	726	779	380	53
350	5	20406	79	96	305	256	797	906	450	93
400	5	26707	104	100	305	292	903	1012	450	126
450	3	20376	79	106	305	308	989	1098	450	160
500	3	25230	98	110	305	340	1101	1210	450	193
600	3	36506	142	110	305	400	1307	1416	450	264
700	2	33288	182	110	335	453	1506	--	--	435
800	2	43788	239	110	335	503	1720	--	--	580
900	2	56064	307	110	335	583	1953	--	--	740
1000	2	69269	379	110	335	613	2137	--	--	925
1200	2	100819	654	150	355	728	2616	--	--	1350

table 5

C.M.O.

Amategui Aldea 142, 20400 Txarama-Tolosa (SPAIN)

TEC-A.EN07

Tel. Nacional: 902.40.80.50 Fax: 902.40.80.51 / Tel. Internacional: 34.943.67.33.99 Fax: 34.943.67.24.40

cmo@cmo.es <http://www.cmo.es>

Page 12

KNIFE-GATE VALVES

A SERIES

CHAINWHEEL

- Widely used in raised installations with difficult access, the handwheel is fitted in vertical position.

- **B = Max. width** of the valve (without actuator)

- Options:

- Locking devices
- Extensions: stand, pipe, plates...
- Non-rising stem
- DN higher than those give in the table

- Including:

- Handwheel
- Stem
- Nut
- Hood

- Available: ND50 to ND1200, other ND on request.

- From DN600 the actuator is with gears, see * in table.

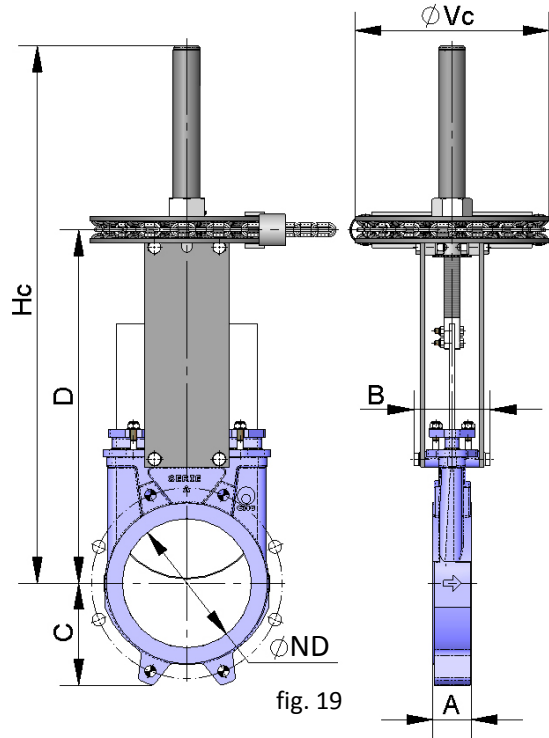

fig. 19

ND	ΔP (Kg/cm ²)	DRAW (Nw)	TORQ. (Nm)	A	B	C	D	Hc	ϕVc	Weight (kg.)
50	10	829	2	40	92	63	264	409	225	7
65	10	1399	3	40	92	70	291	436	225	8
80	10	2119	5	50	92	92	317	469	225	9
100	10	3310	8	50	92	105	357	502	225	11
125	10	5171	12	50	102	120	390	585	225	13
150	10	7448	17	60	102	130	442	644	225	17
200	8	10612	30	60	119	160	551	815	300	29
250	6	12456	36	70	119	198	652	1016	300	40
300	6	17962	51	70	119	234	752	1116	300	53
350	5	20406	79	96	290	256	879	1336	402	93
400	5	26707	104	100	290	292	985	1442	402	126
450	3	20376	79	106	290	308	1071	1628	402	160
500	3	25230	98	110	290	340	1183	1738	402	193
600	3	36506	142	110	290	400	1389	2046	402	264
700	2	33288	182*	110	320	453	1506	2406	402*	435
800	2	43788	239*	110	320	503	1720	2790	402*	580
900	2	56064	307*	110	320	583	1953	3130	402*	740
1000	2	69269	379*	110	320	613	2137	3440	402*	925
1200	2	100819	654*	150	340	728	2616	4050	402*	1350

table 6

C.M.O.

Amategui Aldea 142, 20400 Txarama-Tolosa (SPAIN)

TEC-A.EN07

Tel. Nacional: 902.40.80.50 Fax: 902.40.80.51 / Tel. Internacional: 34.943.67.33.99 Fax: 34.943.67.24.40

cmo@cmo.es <http://www.cmo.es>

Page 13



KNIFE-GATE VALVES

A SERIES

LEVER

- It is a fast actuator
- **B = Max. width** of the valve (without actuator)
P = Max. height of the valve (without actuator)
- The actuator includes:
 - Lever
 - Rod
 - Guide bearing
 - External limiting switches to maintain the position.
- Available: ND50 to ND300, other ND on request.

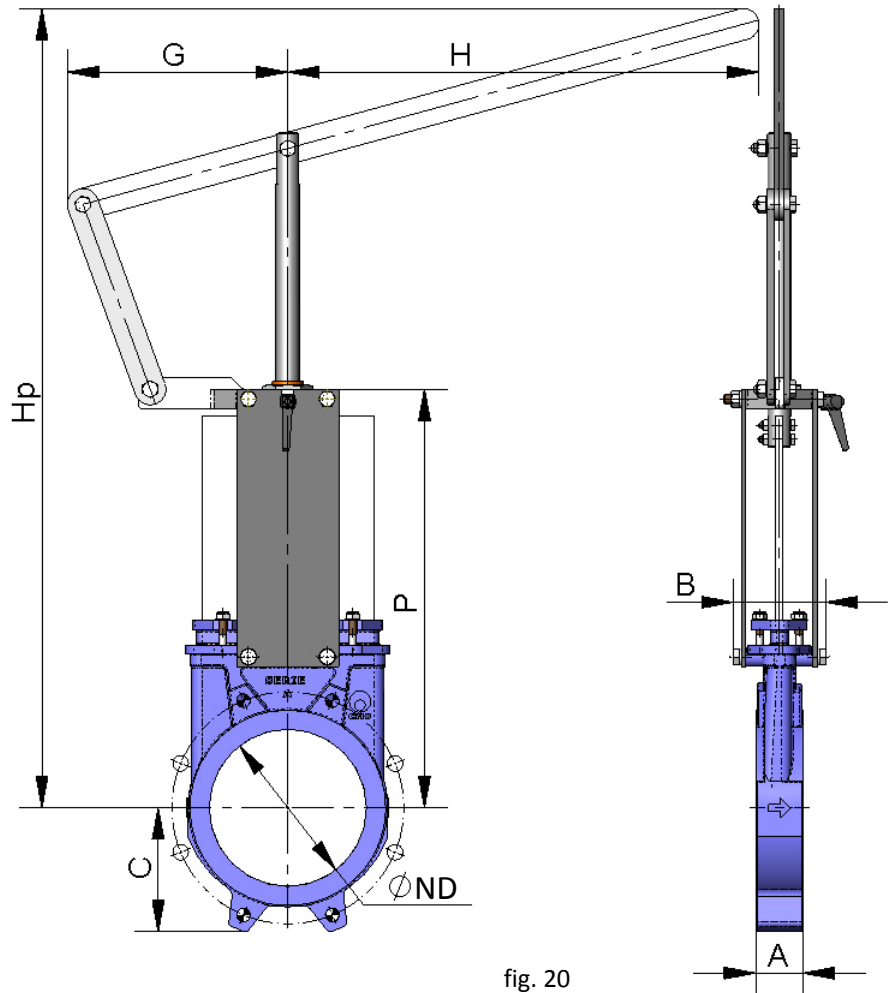

fig. 20

ND	ΔP (Kg/cm ²)	DRAW (Nw)	A	B	C	P	G	H	Hp	Weight (kg.)
50	10	829	40	92	63	264	155	325	504	8
65	10	1399	40	92	70	291	155	325	526	9
80	10	2119	50	92	92	317	155	325	549	10
100	10	3310	50	92	105	357	155	325	605	11
125	10	5171	50	102	120	390	155	425	902	14
150	10	7448	60	102	130	442	155	425	956	16
200	8	10612	60	119	160	551	290	620	1027	32
250	6	12456	70	119	198	652	290	620	1416	54
300	6	17962	70	119	234	752	290	620	1525	57

table 7



KNIFE-GATE VALVES

A SERIES

GEAR BOX

- It is recommendable for DN greater than 600.
- **B = Max. width** of the valve (without actuator)
P = Max. height of the valve (without actuator)
- Options:
 - Chainwheel
 - Locking devices
 - Extensions: stand, pipe, plates...
 - Non-rising stem
- Actuator including:
 - Stem
 - Yoke
 - Cone-shaped gear box
 - Handwheel
- Standard ratio = 4 to 1.
- Available: ND 50 to ND 2000, other ND on request.

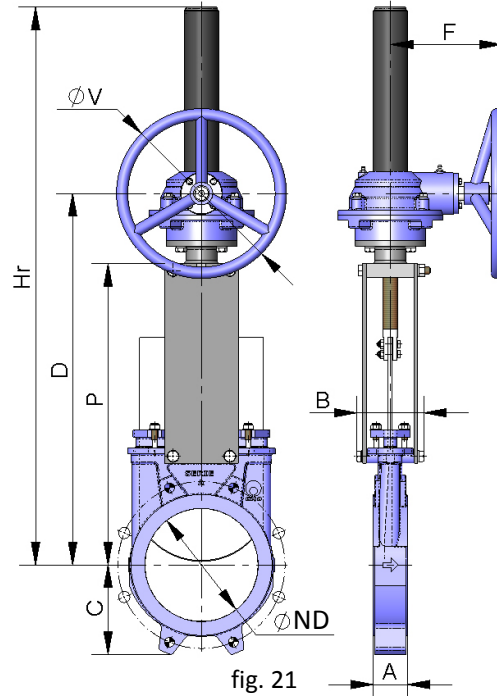

fig. 21

DN	ΔP (Kg/cm ²)	DRAW (Nw)	TORQ. (Nm)	A	B	C	P	D	F	ϕV	Hr	Weight (kg.)
50	10	829	2	40	92	63	241	366	198	300	540	17
65	10	1399	3	40	92	70	268	392	198	300	566	18
80	10	2119	5	50	92	92	294	418	198	300	592	19
100	10	3310	8	50	92	105	334	458	198	300	632	20
125	10	5171	12	50	102	120	367	491	198	300	665	24
150	10	7448	17	60	102	130	419	543	198	300	717	26
200	8	10612	30	60	119	160	525	648	198	300	942	50
250	6	12456	36	70	119	198	626	749	198	300	1043	63
300	6	17962	51	70	119	234	726	850	198	300	1194	77
350	5	20406	79	96	290	256	797	891	218	450	1335	106
400	5	26707	104	100	290	292	903	997	218	450	1441	134
450	3	20376	79	106	290	308	989	1083	218	450	1677	173
500	3	25230	98	110	290	340	1101	1195	218	450	1789	216
600	3	36506	142	110	290	400	1307	1401	218	450	2045	284
700	2	33288	182	110	320	453	1506	1612	260	450	2401	430
800	2	43788	239	110	320	503	1720	1825	288	650	2715	615
900	2	56064	307	110	320	583	1953	2055	288	650	3043	768
1000	2	69269	379	110	320	613	2137	2246	288	650	3351	972
1100	2	83794	544	150	340	670	2375	2515	352	850	3675	1142
1200	2	100819	654	150	340	728	2616	2760	352	850	4042	1298
1300	2	118409	768	150	390	787	2882	3022	352	850	4382	1400
1400	2	137297	891	150	390	837	3250	3388	352	850	4852	N.D.
1500	2	159330	1034	170	426	890	3517	3661	352	850	5217	N.D.
1600	2	181408	1362	170	426	957	3775	4052	382	650	5575	N.D.
1700	2	204754	1537	190	440	1010	4008	4298	412	850	5908	N.D.
1800	2	232230	1952	190	440	1057	4242	4528	412	850	6242	N.D.
1900	2	258699	2175	210	480	1110	4390	4668	432	1000	6490	N.D.
2000	2	286596	2409	210	480	1162	4540	4830	432	1000	6740	N.D.

N.D.: Weight not given

table 8

C.M.O.

Amategui Aldea 142, 20400 Txarama-Tolosa (SPAIN)

TEC-A.EN07

Tel. Nacional: 902.40.80.50 Fax: 902.40.80.51 / Tel. Internacional: 34.943.67.33.99 Fax: 34.943.67.24.40

cmo@cmo.es <http://www.cmo.es>

KNIFE-GATE VALVES

A SERIES

DOUBLE-ACTING PNEUMATIC CYLINDER

- The air supply pressure to the pneumatic cylinder is a minimum of 6 Kg/cm² and a maximum of 10 Kg/cm², the air must be dry and lubricated.
- 10 Kg/cm² is the maximum admissible air pressure. For air pressures below 6 Kg/cm² please consult to **C.M.O.**
- For ND50 to ND200 valves, the cylinder's jacket and covers are made of aluminium, the rod of AISI304, the piston of rubber-coated steel and the O-ring seals are made of nitrile.
- For valves larger than ND200 the covers are made of nodular cast iron or carbon steel.
- On request, we can also supply the actuator made entirely of stainless steel, especially for installation in corrosive atmospheres.
- **B = Max. width** of the valve (without actuator)
- Available: ND50 to ND1200, other ND on request.

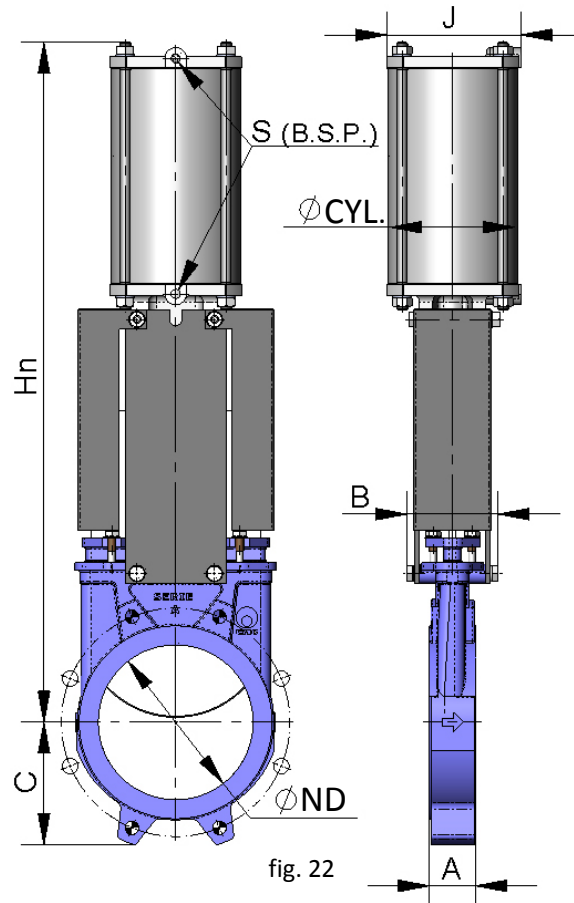

fig. 22

ND	ΔP (Kg/cm ²)	DRAW (Nw)	A	B	C	Ø CYL.	Ø ROD	J	S (B.S.P.)	Hn	Weight (kg.)
50	10	829	40	92	63	80	20	96	1/4"	415	7
65	10	1399	40	92	70	80	20	96	1/4"	455	8
80	10	2119	50	92	92	80	20	96	1/4"	498	9
100	10	3310	50	92	105	100	20	115	1/4"	565	12
125	10	5171	50	102	120	125	25	138	1/4"	636	18
150	10	7448	60	102	130	125	25	138	1/4"	717	22
200	8	10612	60	119	160	160	30	175	1/4"	874	37
250	6	12456	70	119	198	200	30	218	3/8"	1036	58
300	6	17962	70	119	234	200	30	218	3/8"	1182	72
350	5	20406	96	290	256	250	40	270	3/8"	1380	130
400	5	26707	100	290	292	250	40	270	3/8"	1530	155
450	3	20376	106	290	308	300	45	382	1/2"	1677	225
500	3	25230	110	290	340	300	45	382	1/2"	1839	257
600	3	36506	110	290	400	300	45	382	1/2"	2146	340
700	2	33288	110	320	453	350	45	426	1/2"	2481	556
800	2	43788	110	320	503	350	45	426	1/2"	2798	679
900	2	56064	110	320	583	400	50	508	1/2"	3167	840
1000	*	*	110	320	613	400	50	508	1/2"	3451	1053
1100	*	*	150	340	670	400	50	508	1/2"	3792	1210
1200	*	*	150	340	728	400	50	508	1/2"	4135	1366

* → Consult

table 9

C.M.O.

Amategui Aldea 142, 20400 Txarama-Tolosa (SPAIN)

TEC-A.EN07

Tel. Nacional: 902.40.80.50 Fax: 902.40.80.51 / Tel. Internacional: 34.943.67.33.99 Fax: 34.943.67.24.40

cmo@cmo.es <http://www.cmo.es>

Page 16

KNIFE-GATE VALVES

A SERIES

SINGLE-ACTING PNEUMATIC CYLINDER

- The air supply pressure to the pneumatic cylinder is a minimum of 6 Kg/cm² and a maximum of 10 Kg/cm², the air must be dry and lubricated.
- 10 Kg/cm² is the maximum admissible air pressure. For air pressures below 6 Kg/cm² please consult to **C.M.O.**
- Available for opening or closing in case of failure (spring opening or closing).
- The jacket is made of aluminium, the covers of nodular cast iron or carbon steel, the rod of AISI304, the piston of rubber-coated steel, the O-ring seals of nitrile and the spring is made of steel.
- The actuator design is spring activated for valves with diameters up to ND300. For larger diameters the actuator contains a double-acting cylinder and an air tank which stores the volume of air necessary to perform the last movement in the event of a fault.
- **B = Max. width** of the valve (without actuator)
- Available: ND50 to ND300, other ND on request.

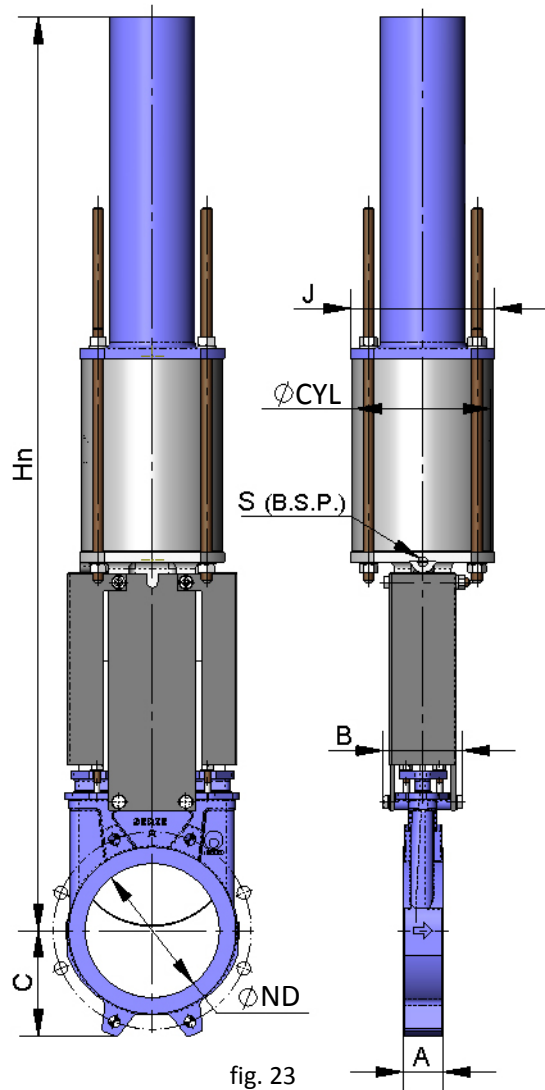

fig. 23

ND	ΔP (Kg/cm ²)	DRAW (Nw)	A	B	C	Ø CYL.	Ø ROD	J	S (B.S.P.)	Hn	Weight (kg.)
50	10	829	40	92	63	125	25	138	1/4"	781	19
65	10	1399	40	92	70	125	25	138	1/4"	806	22
80	10	2119	50	92	92	125	25	138	1/4"	833	23
100	10	3310	50	92	105	125	25	138	1/4"	873	24
125	10	5171	50	102	120	160	30	175	1/4"	909	35
150	10	7448	60	102	130	160	30	175	1/4"	960	36
200	8	10612	60	119	160	200	30	218	3/8"	1355	66
250	6	12456	70	119	198	250	40	270	3/8"	1844	130
300	6	17962	70	119	234	250	40	270	3/8"	2005	143

table 10

C.M.O.

Amategui Aldea 142, 20400 Txarama-Tolosa (SPAIN)

TEC-A.EN07

Tel. Nacional: 902.40.80.50 Fax: 902.40.80.51 / Tel. Internacional: 34.943.67.33.99 Fax: 34.943.67.24.40

cmo@cmo.es <http://www.cmo.es>

Page 17

KNIFE-GATE VALVES

A SERIES

ELECTRIC ACTUATOR

- This actuator is automatic and includes the following parts:
 - Electric motor
 - Stem
 - Yoke
- The electric motor includes:
 - Emergency manual handwheel
 - Limit switches
 - Torque switches
- Options:
 - Different types and brands
 - Non-rising stem
- ISO 5210 / DIN 3338 Flanges
- Available: ND 50 to ND 2000, other ND on request.
- From DN500 the motor is assisted with a gear box.

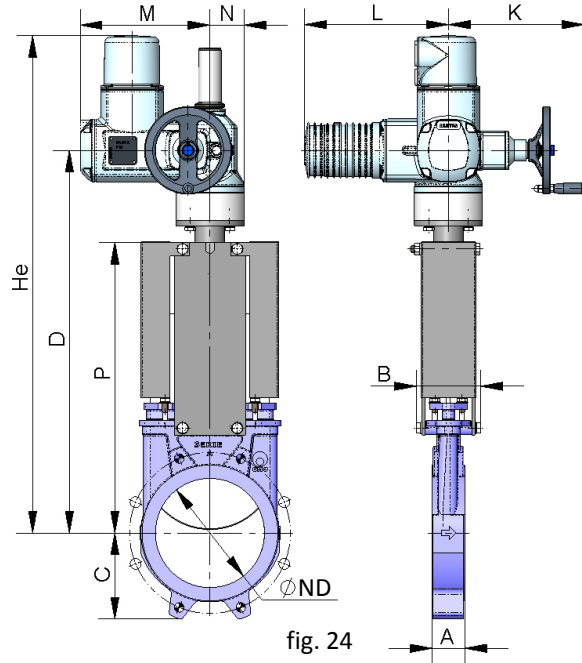

fig. 24

ND	ΔP (Kg/cm ²)	DRAW (Nw)	TORQ. (Nm)	A	B	C	D	K	L	M	N	P	He	Weight (kg.)
50	10	829	2	40	92	63	400	249	265	238	62	241	595	24
65	10	1399	3	40	92	70	426	249	265	238	62	268	622	25
80	10	2119	5	50	92	92	452	249	265	238	62	294	647	26
100	10	3310	8	50	92	105	492	249	265	238	62	334	687	27
125	10	5171	12	50	102	120	525	249	265	238	62	367	720	30
150	10	7448	17	60	102	130	577	249	265	238	62	419	772	32
200	8	10612	30	60	119	160	685	249	265	238	62	525	990	42
250	6	12456	36	70	119	198	785	249	265	238	62	626	1090	55
300	6	17962	51	70	119	234	885	249	265	238	62	726	1190	72
350	5	20406	79	96	290	256	940	254	283	248	65	797	1305	99
400	5	26707	104	100	290	292	1045	254	283	248	65	903	1460	136
450	3	20376	79	106	290	308	1175	336	389	286	91	989	1755	166
500	3	25230	98	110	290	340	1290	336	389	286	91	1101	1870	245
600	3	36506	142	110	290	400	1495	336	389	286	91	1307	2045	362
700	2	33288	182	110	320	453	1661	336	389	286	91	1506	2401	432
800	2	43788	239	110	320	503	1875	339	389	286	91	1720	2715	630
900	2	56064	307	110	320	583	2108	339	389	286	91	1953	3043	764
1000	2	69269	379	110	320	613	2292	339	389	286	91	2137	3351	998
1100	2	83794	544	150	340	670	2530	339	389	286	91	2375	3675	1194
1200	2	100819	654	150	340	728	2760	336	389	528	125	2616	4042	1350
1300	2	118409	768	150	390	787	3022	336	389	528	125	2882	4382	1452
1400	2	137297	891	150	390	837	3388	339	389	528	125	3250	4852	N.D.
1500	2	159330	1034	170	426	890	3661	339	389	528	125	3517	5217	N.D.
1600	2	181408	1362	170	426	957	4052	339	389	570	170	3775	5575	N.D.
1700	2	204754	1537	190	440	1010	4298	339	389	570	170	4008	5908	N.D.
1800	2	232230	1952	190	440	1057	4528	336	389	646	170	4242	6242	N.D.
1900	2	258699	2175	210	480	1110	4668	336	389	646	170	4390	6490	N.D.
2000	2	286596	2409	210	480	1162	4830	339	389	646	170	4540	6740	N.D.

N.D.: Weight not given

table 11

C.M.O.

Amategui Aldea 142, 20400 Txarama-Tolosa (SPAIN)

TEC-A.EN07

Tel. Nacional: 902.40.80.50 Fax: 902.40.80.51 / Tel. Internacional: 34.943.67.33.99 Fax: 34.943.67.24.40

cmo@cmo.es <http://www.cmo.es>

Page 18



KNIFE-GATE VALVES

A SERIES

HYDRAULIC ACTUATOR (Oil pressure: 135 Kg/cm²)

- **B = Max. width** of the valve (without actuator)
- The hydraulic actuator includes:
 - Hydraulic cylinder
 - Puente
- Available: ND 50 a ND 2000
- Different types and brands available according to customer's requirements.

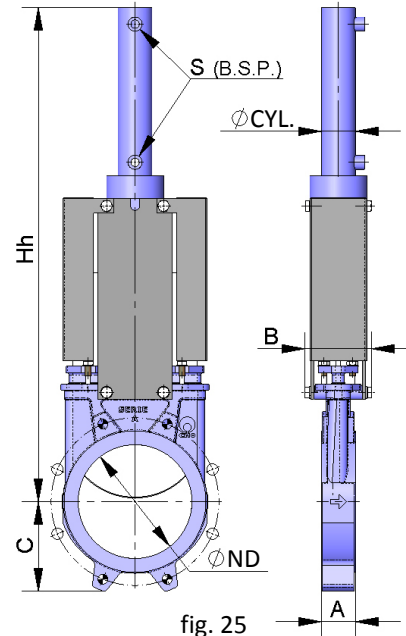

fig. 25

ND	ΔP Kg/cm ²	DRAW (Nw)	A	B	C	Hh	Ø CYL.	S (B.S.P.)	Oil Cap. (dm ³)	Ø ROD	Weight (kg.)
50	10	829	40	92	63	460	25	3/8"	0.03	18	7
65	10	1399	40	92	70	500	25	3/8"	0.03	18	8
80	10	2119	50	92	92	560	25	3/8"	0.04	18	9
100	10	3310	50	92	105	620	32	3/8"	0.09	22	12
125	10	5171	50	102	120	683	32	3/8"	0.11	22	15
150	10	7448	60	102	130	755	40	3/8"	0.20	28	20
200	8	10612	60	119	160	926	50	3/8"	0.42	28	31
250	6	12456	70	119	198	1077	50	3/8"	0.52	28	44
300	6	17962	70	119	234	1245	50	3/8"	0.62	28	62
350	5	20406	96	290	256	1376	50	3/8"	0.73	28	100
400	5	26707	100	290	292	1535	63	3/8"	1.31	36	138
450	3	20376	106	290	308	1710	63	3/8"	1.47	36	161
500	3	25230	110	290	340	1870	63	3/8"	1.62	36	223
600	3	36506	110	290	400	2175	80	3/8"	3.12	45	325
700	2	33288	110	320	453	2525	80	3/8"	3.62	45	481
800	2	43788	110	320	503	2839	100	1/2"	6.44	56	678
900	2	56064	110	320	583	3172	100	1/2"	7.25	56	861
1000	2	69269	110	320	613	3496	125	1/2"	10.25	70	1103
1100	2	83794	150	340	670	3760	125	1/2"	13.56	70	1266
1200	2	100819	150	340	728	4174	125	1/2"	15.05	70	1430
1300	2	118409	150	390	787	4451	160	1/2"	26.3	70	1647
1400	2	137297	150	390	837	4939	160	1/2"	28.65	70	N.D.
1500	2	159330	170	426	890	5286	160	1/2"	30.7	70	N.D.
1600	2	181408	170	426	957	5658	160	1/2"	32.7	70	N.D.
1700	2	204754	190	440	1010	5991	200	1/2"	53.72	90	N.D.
1800	2	232230	190	440	1057	6325	200	1/2"	57.35	90	N.D.
1900	2	258699	210	480	1110	6578	200	1/2"	60.16	90	N.D.
2000	2	286596	210	480	1162	6828	200	1/2"	63.65	90	N.D.

N.D.: Weight not given

table 12

C.M.O.

Amategui Aldea 142, 20400 Txarama-Tolosa (SPAIN)

TEC-A.EN07

Tel. Nacional: 902.40.80.50 Fax: 902.40.80.51 / Tel. Internacional: 34.943.67.33.99 Fax: 34.943.67.24.40

cmo@cmo.es <http://www.cmo.es>

Page 19

KNIFE-GATE VALVES

A SERIES

INFORMATION ON FLANGE DIMENSIONS

EN 1092-2 PN10

ND	ΔP (Kg/cm ²)	•	O	Metric	Prof	ϕK
50	10	4	-	M 16	8	125
65	10	4	-	M 16	8	145
80	10	4	4	M 16	9	160
100	10	4	4	M 16	9	180
125	10	4	4	M 16	9	210
150	10	4	4	M 20	10	240
200	8	4	4	M 20	10	295
250	6	6	6	M 20	12	350
300	6	6	6	M 20	12	400
350	5	10	6	M 20	21	460
400	5	10	6	M 24	21	515
450	3	14	6	M 24	22	565
500	3	14	6	M 24	22	620
600	3	14	6	M 27	22	725
700	2	16	8	M 27	22	840
800	2	16	8	M 30	22	950
900	2	20	8	M 30	20	1050
1000	2	20	8	M 33	20	1160
1100	2	20	12	M 33	20	1270
1200	2	20	12	M 36	22	1380
1300	2	20	12	M 36	26	1490
1400	2	24	12	M 39	26	1590
1500	2	24	12	M 39	35	1700
1600	2	28	12	M 45	40	1820
1700	2	30	14	M 45	40	1920
1800	2	30	14	M 45	40	2020
1900	2	32	16	M 45	45	2120
2000	2	32	16	M 45	45	2230

table 13

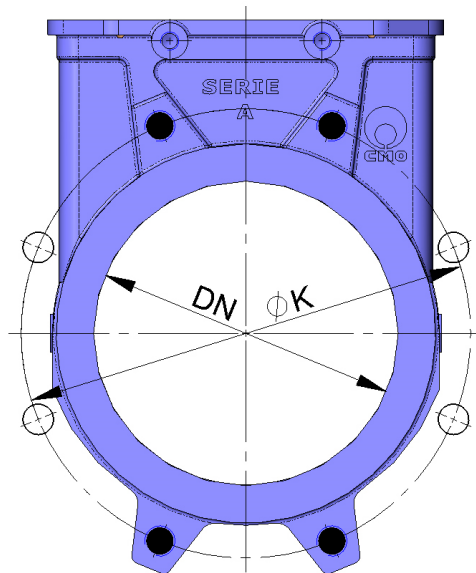

fig. 26

- BLIND TAPPED HOLES
- THROUGH HOLE

ANSI B16, class 150

ND	ΔP (Kg/cm ²)	•	O	R UNC	Prof.	ϕK
2"	10	4	-	5/8"	8	120,6
2 1/2"	10	4	-	5/8"	8	139,7
"	10	4	-	5/8"	9	152,4
4"	10	4	4	5/8"	9	190,5
5"	10	4	4	3/4"	9	215,9
6"	10	4	4	3/4"	10	241,3
8"	8	4	4	3/4"	10	298,4
10"	6	6	6	7/8"	12	361,9
12"	6	6	6	7/8"	12	431,8
14"	5	8	4	1"	21	476,2
6"	5	10	6	1"	21	539,7
18"	3	10	6	1 1/8"	22	577,8
20"	3	14	6	1 1/8"	22	635
24"	3	14	6	1 1/8"	22	749,3
28"	2	20	8	1 1/8"	22	863,6
30"	2	20	8	1 1/8"	22	914,4
32"	2	18	10	1 1/2"	22	977,9
36"	2	20	12	1 1/2"	20	1085,9
40"	2	24	12	1 1/2"	20	1200,2

table 14

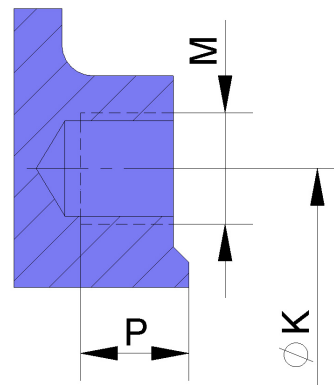

fig. 27

C.M.O.

Amategui Aldea 142, 20400 Txarama-Tolosa (SPAIN)

TEC-A.EN07

Tel. Nacional: 902.40.80.50 Fax: 902.40.80.51 / Tel. Internacional: 34.943.67.33.99 Fax: 34.943.67.24.40

cmo@cmo.es <http://www.cmo.es>

Page 20