

Angle Cryogenic Safety Valve

ST-102E Rev.0.1

S3200

Maximum Pressure
150 Barg
Temperature
-200/+400°C



The safety valves S3200 have angle screwed connections M/F NPT(ANSI B 1.20.1) or GAS (BSP ISO228/1). They are suitable to be used with cryogenic fluids up to -200°C or with high temperature fluids up to +400°C.

The valve design ensures the achievement of a set

pressure of 150 bar with a rating class 900. The stem is guided in the upper part stream and the disk has the blowdown ring.

The valves are manufactured according to ASME B16.34 and comply with 97/23/EC (PED) standard requirements.

Materials

Body/Bonnet	BR.AL/A351CF3
Trim	AISI 316 / 304
Stem	AISI 304
Spring	AISI 316

Models/Connections

S32001	1/2" x 1" MF - NPT o Gas
S32002	3/4" x 1" MF - NPT o Gas
S32003	1" x 1" MF - NPT o Gas
S32004	1" x 1" MF - NPT o Gas



Operating Conditions

MOP	Max Operative Pressure 160 Barg
MOT	Max Operative Temperature -200/+400°C

Accessories

- Test gag
- Lever with or without packing

Applications

- Suitable for cryogenic fluids
- Liquid Oxygen -196°C
- Liquid Nitrogen -196°C
- Air
- LPG & LNG

Characteristics

- | | | |
|--|--|---|
| <ul style="list-style-type: none"> • Angle body • Blowdown ring • Suitable for cryogenic fluids | <ul style="list-style-type: none"> • Stem/Plug Guided • Screwed connections M/F • Max Inlet rating ANSI 900 | <ul style="list-style-type: none"> • Max Outlet rating ANSI 300 • Orifice 8.1 mm & 10 mm • PED Certificate IV Cat. |
|--|--|---|

S3200 - Angle Cryogenic Safety Valve

Overall Dimensions and Technical Characteristic

TYPE	Connections		Orifice			Lift mm	Min. Thick. (S) mm	DIMENSIONI			
	Inlet F	Outlet F	Ø mm	Cm2	Sq.inc			A	B	C	
										STD	LEVER
32001	½"	1"	8.1	0.516	0.08	2	5.5	52	77	255	275
32002	¾"	1"	8.1	0.516	0.08	2	10	52	77	255	275
32003	1"	1"	8.1	0.516	0.08	2	10.5	52	77	255	275
32004	1"	1"	10	0.785	0.121	2.5	10.5	52	77	255	275

Operating Characteristic

Discharge Coefficient K	Liquids	Gas
	0,62	0,94
Overpressure	Liquids	Gas
	10%	10%

Accessories

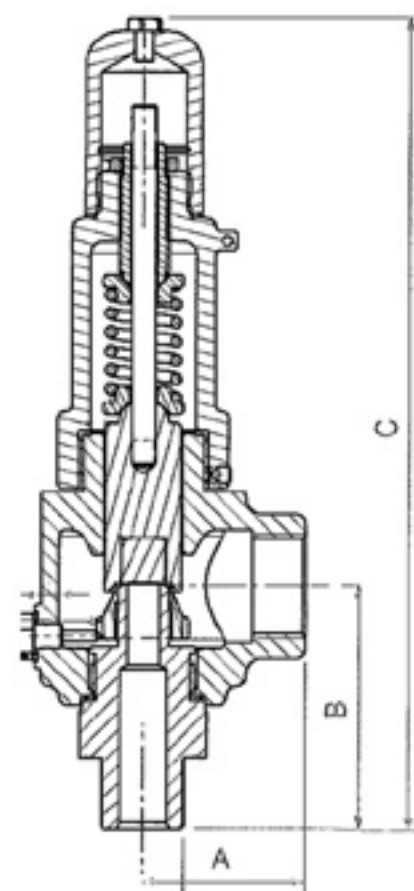
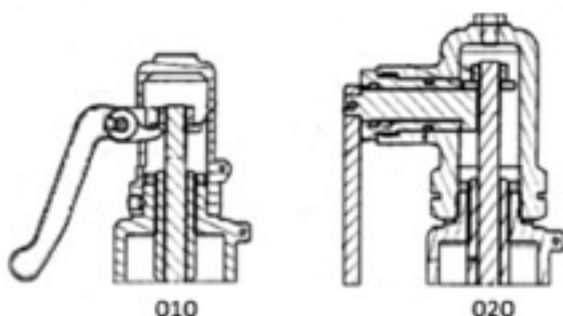

Certifications

CE 97/23/CE (PED)

PG **PG** GOST R N.9239

UNI EN ISO 9001:2008
ICIM Certificato N. 0075/5

Ex ATEX EX II2G