

# Datasheet

## Ball segment valve

# Si-103 EN

Edition: 2016-04

### Type KVT / K VX

**Nominal pressure**

**Nominal size**

**Material**

### Flanged design

**PN 10**

**DN 450 - 700**

**Stainless steel**

- **Control and tight shut-off valve**
- **High capacity**
- **Ball segment and shaft in one piece gives a torque transmission free of backlash**
- **Excellent tightness irrespective of differential pressure**

The SOMAS ball segment valve type KVT with a centrally mounted ball segment and K VX with an eccentrically mounted ball segment are flanged.

The valve body is diagonally split. Ball segment and shaft are made in one piece. The spring-loaded seat offers excellent tightness also at low differential pressure.

The valves can be used for control, as well as for shut-off applications, of practically every type of media within a wide temperature range. Choose KVT for liquids, media containing impurities, sludge and chemicals. For dry media such as steam, gases and acids, choose K VX. In the K VX-valve the ball segment is eccentrically mounted and rotates out from the seat when the valve is opened. This reduce the wear on seat and segment.

The SOMAS valves are delivered ready for installation and operation. The valve assemblies are delivered factory tested as complete units with actuators, positioners and accessories.





### Tightness class

The tightness class is related to the chosen material in the seat ring.

PTFE seat	Code A	EN 60534-4 VI (ASME B16-104 Class VI)
PTFE 53 seat <sup>1</sup>	Code B	EN 60534-4 VI (ASME B16-104 Class VI)
HiCo seat <sup>2</sup>	Code T	EN 60534-4 IV or better (ASME B16-104 Class V)

<sup>1</sup> 50% PTFE + 50% 1.4435 (316L) powder (percentage by weight)

<sup>2</sup> HiCo (High Cobalt alloy)

### Pressure and temperature rating

According to the material in the seat.

Seat Code	Max. working pressure <sup>1</sup> (bar at ° C)				
	150°	170°	200°	280°	>280°
<b>A</b>	10	8	–	–	–
<b>B</b>	10	10	6	–	–
<b>T</b>	10	10	8	7	Note 1

10 bar = 1 MPa

Note 1: Check with SOMAS

<sup>1</sup> **NB!** Do not exceed working pressure for the valve.

### Flow characteristics

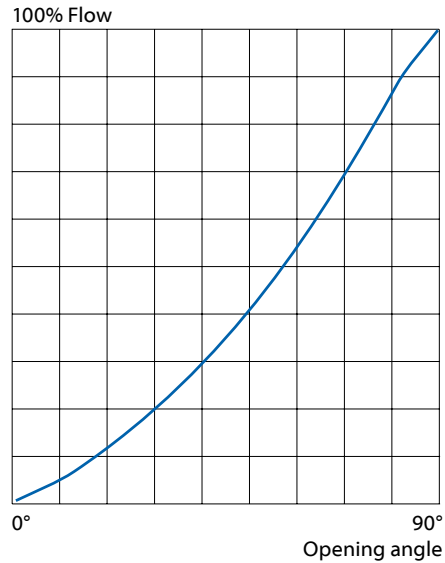

### Capacity factor Kv and Resistance factor $\xi$ for ball segment valve type KVT

DN	Opening angle									$\xi$ 90°
	10°	20°	30°	40°	50°	60°	70°	80°	90°	
<b>450</b>	434	1099	1909	2902	3934	5225	6575	8388	9640	0,71
<b>500</b>	656	1663	2888	4390	5951	7906	9948	12690	14585	0,47
<b>600</b>	950	2407	4181	6356	8616	11446	14402	18372	21120	0,46
<b>700</b>	1292	3275	5690	8650	11725	15575	19600	25000	28740	0,46

### Capacity factor Kv and Resistance factor $\xi$ for ball segment valve type KVX

DN	Opening angle									$\xi$ 90°
	10°	20°	30°	40°	50°	60°	70°	80°	90°	
<b>450</b>	275	840	1575	2490	3485	4600	5985	7960	9250	0,78
<b>500</b>	415	1275	2380	3765	5275	6960	9050	12040	13850	0,52

Relation between Kv and Cv:  $Kv = 0.86 \times Cv$

### Flanged design

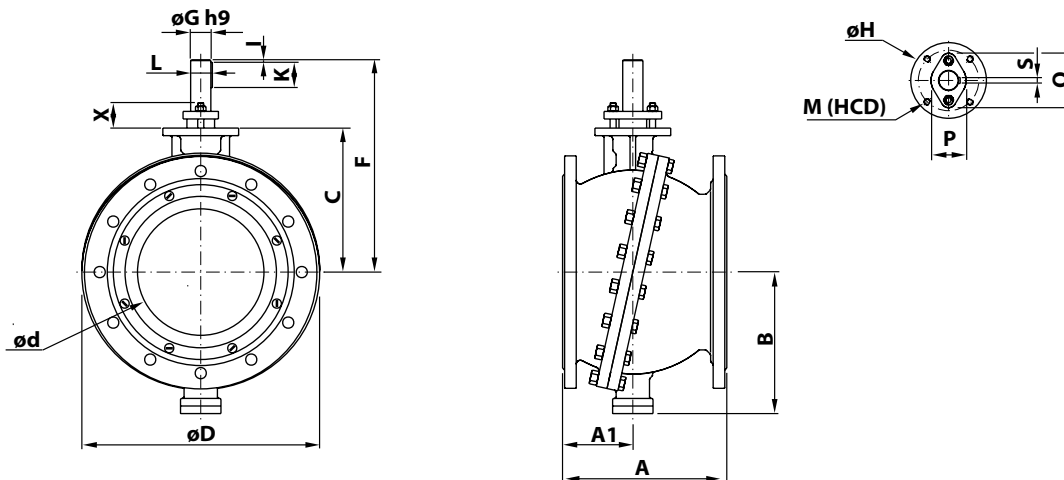

Mounting dimension according to EN 558-1 series 20 and EN 558-2 series 20.

Ball segment valve KVT/KVX, PN 10

DN	A	A1	B	C	ød	øD	E	(F)	øG	øH	I	K	L	M	HCD	O	P	S	X	Weight
<b>450</b>	550	245	445	460	400	Acc. to flange standard	175	635	60	200	10	90	64	M12	120	147	96	18	60	345
<b>500</b>	715	335	525	540	492		225	765	70	200	10	110	75	M16	160	162	112	20	60	575
<b>600</b>	850	395	625	640	588		245	885	80	200	10	120	85	M16	160	183	120	22	76	710
<b>700</b>	960	440	708	725	690		255	980	100	250	10	125	106	M20	205	195	195	28	72	1180



## Flanged design

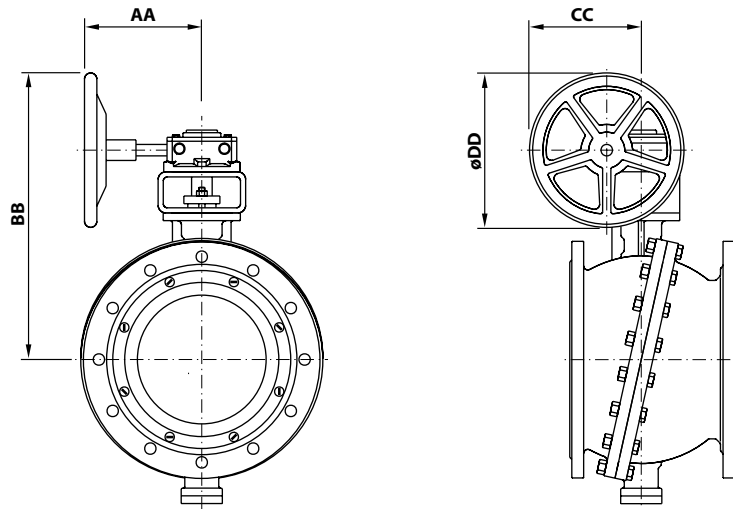

Ball segment valve, with gear unit

DN	Type	AA	BB	CC	øDD	Weight
450	M15/F16	330	860	350	430	385
500	MJF/S5	530	1030	400	610	685
600	MJF/S5	530	1130	400	610	820
700	MJF/S5	530	1215	400	610	1290

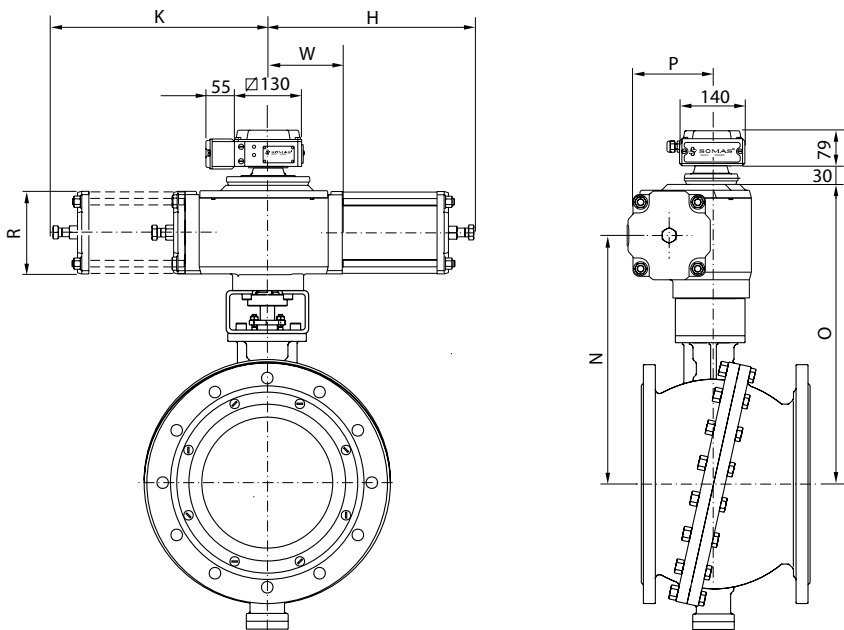

Ball segment valve type KVT/KVX with actuator type A-DA

DN	Type	H	K	N	O	P	R	W	Weight
450	A42	545	560	755	860	210	230	-	440
500	A42	545	560	815	940	210	230	-	630
500	A43	680	-	815	940	280	355	315	725
600	A51	745	-	875	1060	314	354	370	915
700	A51	745	-	960	1145	314	354	370	1385
700	A52	745	760	960	1145	314	354	-	1420

Actuator type A-SC/SO

DN	Type	H	K	N	O	P	R	W	Weight
450	A44-X	925	935	735	860	279	354	-	575

X = SC – Spring to close

X = SO – Spring to open

For units with the positioner type SP405, add 2 kg

For units with the positioner type SPE405, add 3 kg

For units with the positioner type SP405, add 2 kg  
For units with the positioner type SPE405, add 3 kg



## Flange standard

SOMAS ball segment valves type KVT and KVX in above mentioned sizes are equipped with flanges which can be drilled for PN10.

Drilling according to ASME is also possible.

When ordering, please state required drilling.

NB! Do not exceed the working pressure for the valve.

## Torque

Valve DN	Shaft dia. (mm)	Necessary closing torque	
		Min. (Nm)	Max. (Nm)
450	60	3000	5000
500	70	4400	8000
600	80	5500	12000
700	100	7000	14000

## Selection table

Valve DN	Shaft dia. (mm)	Pneumatic actuators						Manual override	
		Double acting		Spring return				Hand lever	Gear unit
		5.5 bar	4 bar	Spring to close		Spring to open			
		5.5 bar	4 bar	5.5 bar	4 bar	5.5 bar	4 bar		
450	60	A42-DA	A42-DA	A44-SC	A44-SC	A44-SO	A44-SOL	-	M15/F16
500	70	A42-DA	A-43DA					-	MJF/S5
600	80	A51-DA	A51-DA					-	MJF/S5
700	100	A51-DA	A52-DA					-	MJF/S5

## Ordering

State desired valve according to the valve specification system below as well as type of actuator, positioner and accessories.

## Actuators and accessories

The valves can be fitted with SOMAS manual, on/off or control actuators in accordance with the selection table.

The valves will be delivered as tested units ready for installation. See section 3, 4 and 5 of our catalogue, where also actuators, positioners, limit switches and solenoid valves are presented.

We can also fit other types of actuators and accessories in accordance with your specification.

## Further technical information

Technical data for the materials used in the SOMAS valves, flange standard, steam data, etc. can be found in section 6 of the SOMAS catalogue.

## Valve sizing

Use SOMAS valve sizing program SOMSIZE to find the correct valve size. All sizing factors are included in the program.

## Valve specification system

**KVT - L 2 - A K A - A 7 1 - DN... - D... - B... - PN...**

1 2 3 4 5 6 7 8 9 10 11 12 13

### 1 Type of valve

Flanged design

KVT (centrically mounted segment)

KVX (eccentrically mounted segment)

### 2 Valve body design

L = Flanged design

### 3 Nominal pressure

2 = PN 10

### 4 Material - valve body

A = CF8M

B = CF8M, hard chromed

### 5 Material - ball segment

K = 2324-12, hard chromed

L = 2324-12, HiCo coated

### 6 Material - seat

A = PTFE (10 % carbon)

B = PTFE 53<sup>1</sup>

T = HiCo (High Cobalt alloy)

### 7 Material - shaft

A = 2324-12

B = 2324-12, hard chromed

### 8 Bearings - valve body/shaft

7 = 1.4539

### 9 Stuffing box

1 = Graphite

2 = PTFE

### 10 Valve size, DN

### 11 Shaft diameter

### 12 Actuator mounting flange drilling

### 13 Drilling, counter flanges, PN/Class

<sup>1</sup> 50 % PTFE + 50 % 1.4435 (316L) powder (percentage by weight)

*SOMAS reserves the right to make improvements without prior notice.*



**SOMAS**<sup>®</sup>  
www.SOMAS.se

Box 107  
SE-661 23 SÄFFLE  
SWEDEN

Phone: +46 533 167 00  
Fax: +46 533 141 36  
E-mail: sales@SOMAS.se