

Butterfly Valve

---

# Type GD-6

---

## Butterfly Valve Type GD-6 with mounted pneumatic actuator

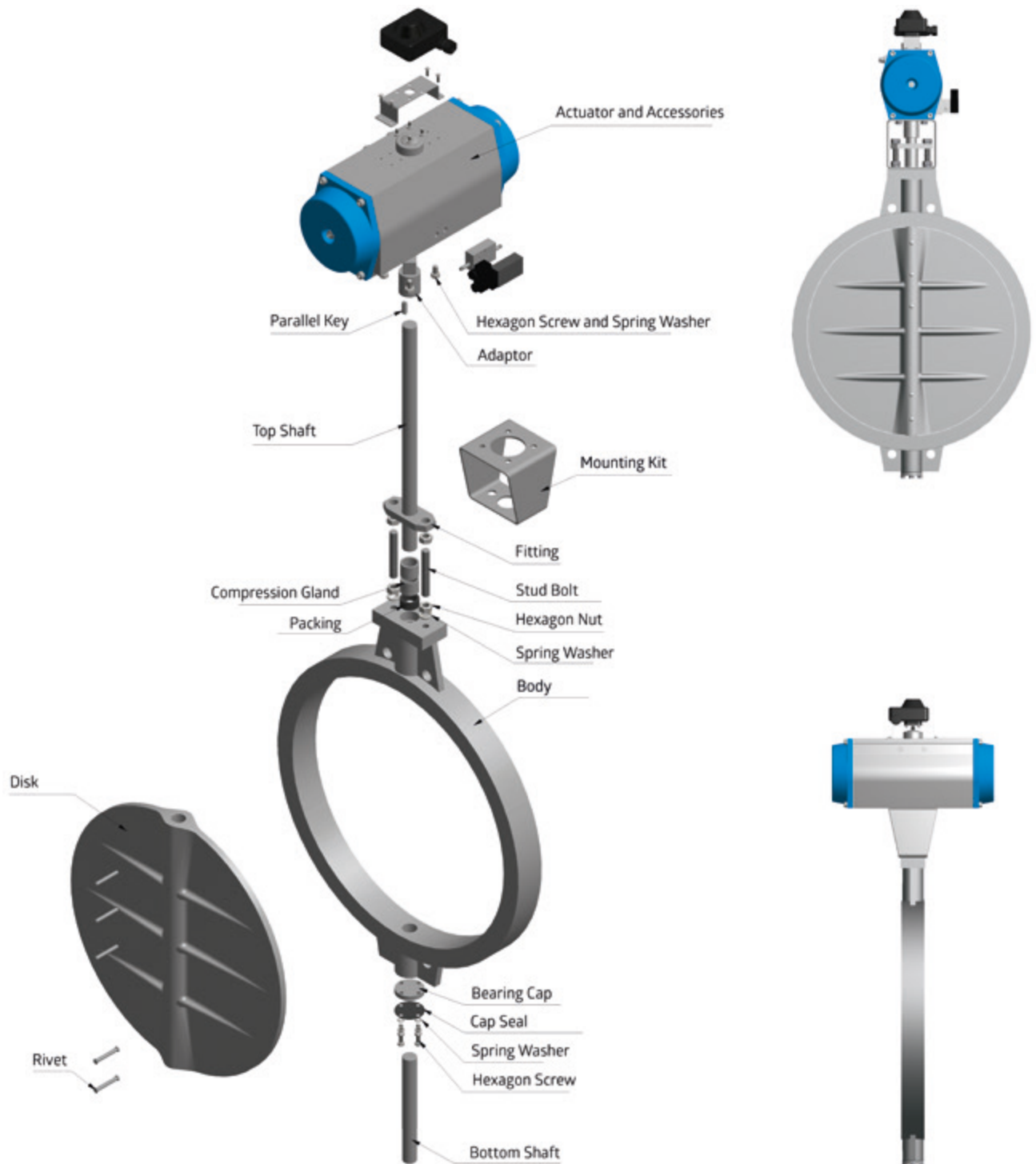

Exploded view of a standard GD-6 with a swing through cast-iron disk and a pneumatic actuator.

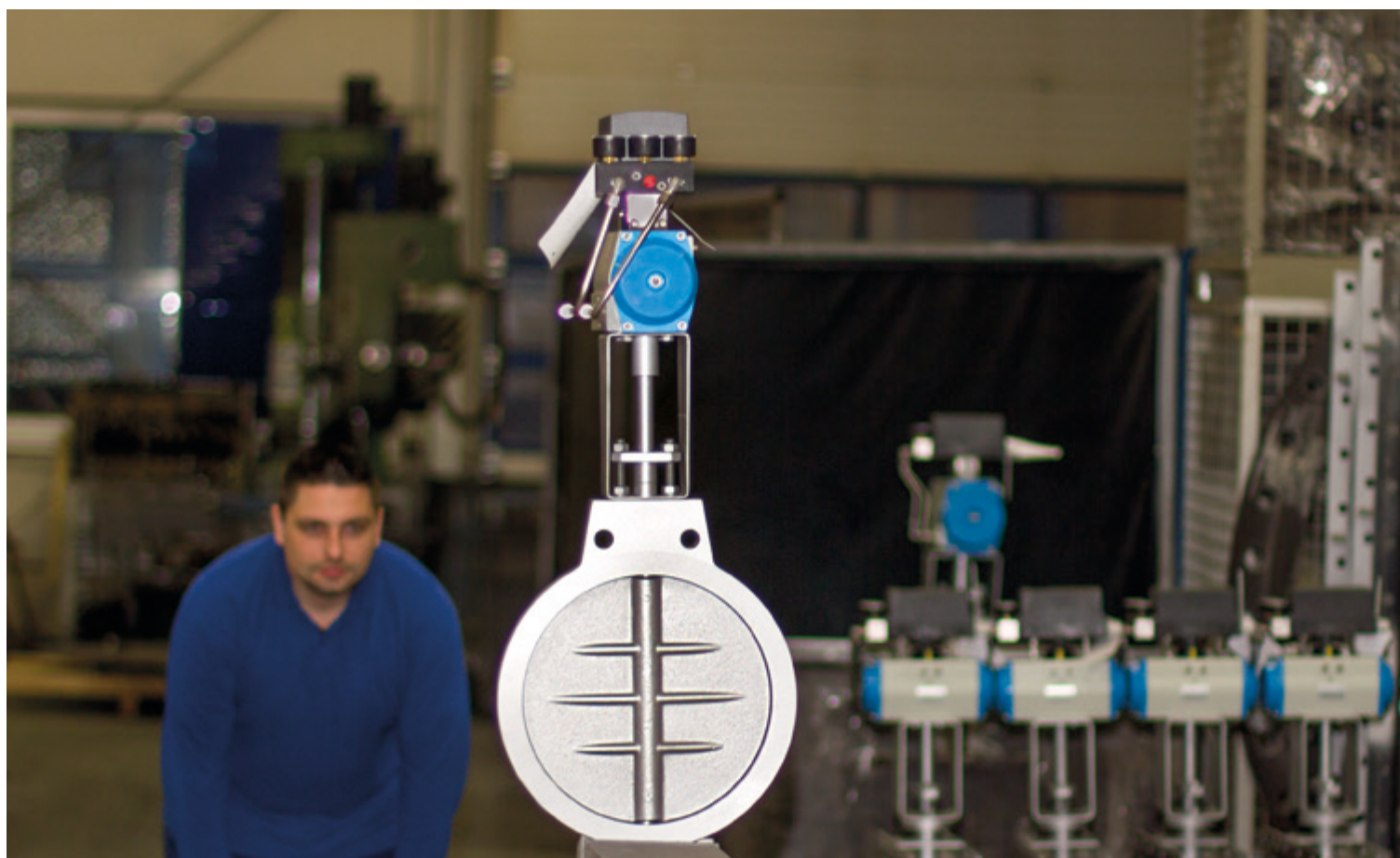

## General Description of the Butterfly Valve Type GD-6

The GD-6 butterfly valve is one of our all-rounders in the fields of control valve technology and shut-off valve technology. They are clamped between flanges (PN-6 to PN-16) in pipelines. We can produce this valve from any materials available on the market, depending on the application (temperature, element, pressure). Custom made orders and customer requests are always possible after consultation.

Special valves which have already been implemented are a water-cooled GD-6 valve and a lever system valve that allows multiple valves to be controlled at once.

With our three sided jacketed sealing gasket we can implement an impermeability of at least 99,95% at high pressure when compared to fully opened valve disks.

We do not only offer our valves with free end-shafts, but can also upon requests offer the valves either as manually operated (with locking mechanism or continuously variable fine adjustment) or an actuator. Any actuator available on the market can be fitted with our DIN ISO 5211 mounting kit. Any further adaption is possible depending on the customer's request.

## Advantages at a glance

Handling	Easy, depending on the accessories
Impermeability	99%, 99,8% and 99,98% compared to fully opened disk
Temperature Application	-100°C to +1100°C
Element Compatibility	Design and material selection according to your element and further operating conditions, including: (aggressive) flue gas, dust laden elements, biogas or exhaust gases from biomass burning
Reliability	Very low possibility of failure
Maintenance Characteristics	Low maintenance

## Basic Information

### Sizes: DN 15 – DN 2000 implemented as a standard

- Up to DN 5000 possible as a custom order

### GD-6 as an intermediate flange design to clamp between flanges according to

- DIN EN 1992-1, PN-6/PN-10/PN-16
- ANSI B 16.5 – 150 lbs / 300 lbs / 400 lbs
- Every clamping possibility available upon request
- Centering aid guarantees an exact fitting in the pipeline

### Operation

- With free shaft-ends
- Manual operation with a grid handle with locking mechanism or continuously variable fine adjustment
- A corresponding shaft adaption with the DIN ISO 5211 mounting kit
- With an attached actuator (pneumatic, electric or hydraulic)

### Shaft Seal

- Gland seal
- O-Rings or shaft seals (EPDM, FPM, NBR, PTFE)
- Smooth running seal
- TA-Luft

### Shaft Bearing

- Friction bearing (EN-GJL-250, RG7, Rhyolite, PTFE, DU)
- External fitting through flange bearings for smooth operating
- External fitting over a friction bearing (EN-GJL-250CrNi-bearing blocks) for high temperatures up to 1100°C

### Impermeability classes

- Approx. 99% impermeability in a swing through design
- Approx. 99% impermeability (metallic sealing) compared to fully opened valve disk in a design with a stop bar in the body
- Approx. 99,98% impermeability (with flexible seal) in designs with a stop bar and three sided jacketed gasket in the body

### Temperature Application

- From -100°C to +1100°C

### Material

- Cast iron (e.g. EN-GJL-250, EN-GJL-250CrNi, 1.4848, 1.4865)
- Steel (e.g. S235JR, S355JR)
- Stainless steel (e.g. 1.4301, 1.4541, 1.4571, 2.4610)
- Heat resistant steel (e.g. 1.4828, 1.4841)
- Aluminium
- Duplex

## GD-6

## Closing Types

Swing through	99% impermeability compared to fully opened disk
With a stop bar in the body	99,5% to 99,8% impermeability compared to fully opened disk
With stop bar and gasket seal	99,95% to 99,98% impermeability compared to fully opened disk
With sealing air	Up to 100% impermeability

## Material Combinations

Temperature	up to 350°C	from 350°C- 450°C	from 450°C- 550°C	from 550°C - 750°C	from 750°C- 1100°C
Body	EN-GJL-250; Alu	EN-GJL-250; EN-GJL-250CrNi; P265GH	EN-GJL-250CrNi; 1.4301; 16Mo3	EN-GJL-250CrNi,	1.4828
Disk	EN-GJL-250; St. 37; 1.4301	EN-GJL-250; 1.4301; P265GH	1.4301; EN-GJL-250CrNi; 16Mo3	1.4541; EN-GJL-250CrNi	1.4828
Shaft	St. 37; 1.4021	1.4021; 1.4541	1.4021; 1.4305; 1.4541	1.4541	1.4828
Subject to modification					

Note: The material combinations listed here are standard combinations. The exact selection is made for special designs and special requests in accordance with specifications or after consulting with you.

## Actuators and Actuator Accessories

Operation	Accessory
Manual operation	Grid handle, fine adjustment, worm gear
Pneumatic actuator	Magnet valve, electro-mechanical end switch, inductive proximity switch positioner 4...20mA, PROFIBUS, HART, etc.
Elektric actuator	End switch, revolution off-switch, position encoder 4...20mA, positioner, PROFIBUS, HART
Security functions	Fast closing and opening <1 sec through express airing or fall weights
Cylinder	Magnet valve, End position control
Subject to modification	

## Advantages of the GD-6

- Our valves are individually produced according to your needs. They are adjusted one hundred percent according to the operational conditions. That includes the specifications, material choice and operation.
- The Kv-values, impermeability and dynamic torque are according to our standards and tested in an FEM simulation. Here the advantages are shown between cast disks and steel disks when it concerns the impermeability of the disk.
- The intermediate flange design GD-6 is produced with a centering aid. This ensures easy installation and centering the valve between the flanges of the pipeline.

## References

- BÜTTNER Gesellschaft für Trocknungs- und Umwelttechnik mbH, Krefeld
- Loesche ThermoProzess GmbH, Gelsenkirchen
- Riedhammer GmbH, Nürnberg

” We are using to sell them to kilns and oven manufacturers that use the valves on smokes and hot air plants. In every situation your valves have given very good results and the customers have been always satisfied of the products.

We hope you will go on to make your valves like you are doing now.

*R. Bovo / Econex, Italy*

## Application Areas

Smelters, foundries, cement factories, crematoriums, industrial ovens (for iron, steel, aluminium and stainless steel), glass factories, factories (for Rockwool, porous concrete etc.), ceramic ovens, drying and dust extractors, gas turbines, heat treatment, and high temperature oven construction.

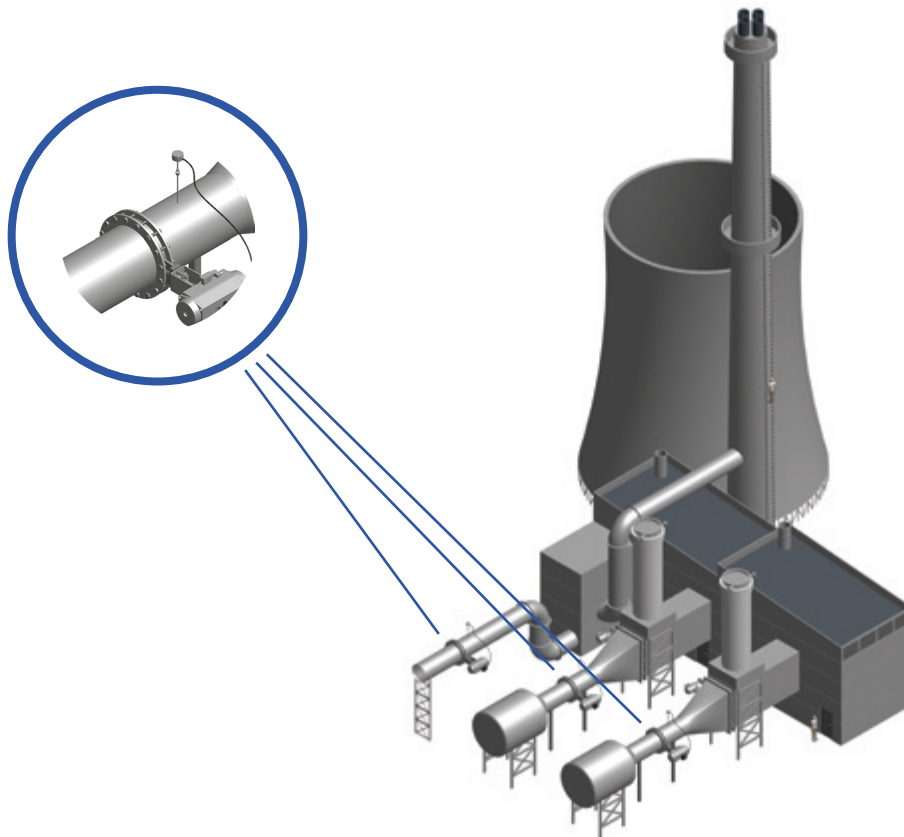

Our delivery supply range: Sensors according to determination of the mass flows. Our flow measurement sensors measure independently from pressure, temperature and element. Further information upon request.

## Standard Measurements GD-6 with Grid Handle

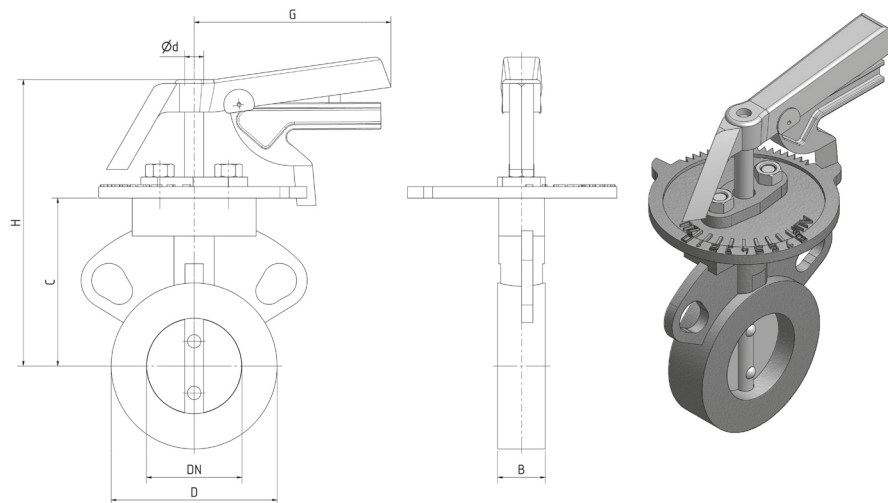

DN	B	C	D	d	G	H	approx. Mass [kg]
15	25	60	44	8	100	130	1
20	25	60	44	8	100	130	1,1
25	25	75	60	10	100	145	1,2
32	25	80	67	10	100	150	1,4
40	25	83	75	10	145	163	1,5
50	25	85	85	10	145	165	1,6
65	30	95	105	12	145	175	2,2
80	30	105	120	12	145	185	2,5
100	30	115	140	12	145	195	2,8
125	35	135	170	12	145	215	4,8
150	40	150	195	15	155	235	5,7
175	40	165	225	15	155	250	7,5
200	40	175	255	15	155	260	8,8
225	40	185	280	15	155	270	11,5
250	40	220	310	15	155	305	13,9
300	45	240	360	20	155	325	22,6
350	45	290	415	25	210	410	27
400	50	335	465	30	210	455	39
450	50	360	520	30	210	480	45
500	55	400	570	30	210	520	56
550	60	420	620	30	210	540	78
600	65	460	675	30	210	580	82



## Standard Measurements GD-6 with Fine Adjustment SFD-6

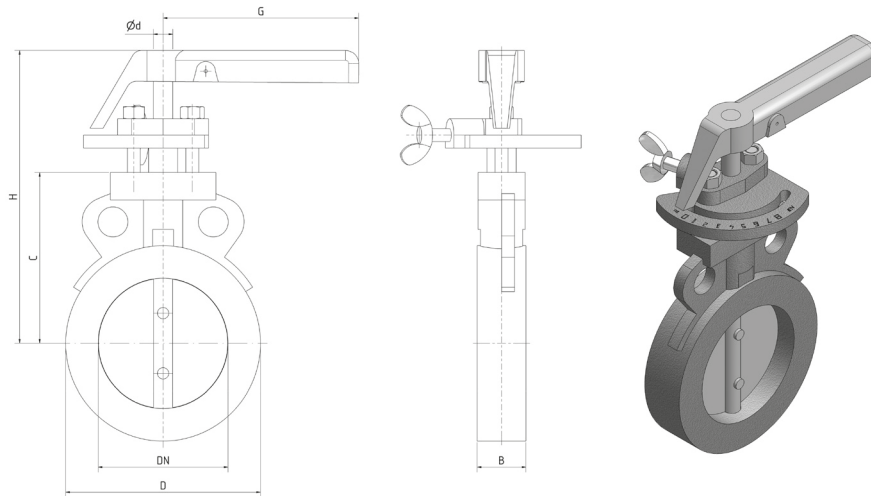

DN	B	C	D	d	G	H	approx. Mass [kg]
15	25	60	44	8	100	130	1
20	25	60	44	8	100	130	1,1
25	25	75	60	10	100	145	1,2
32	25	80	67	10	100	150	1,4
40	25	83	75	10	145	163	1,5
50	25	85	85	10	145	165	1,6
65	30	95	105	12	145	175	2,2
80	30	105	120	12	145	185	2,5
100	30	115	140	12	145	195	2,8
125	35	135	170	12	145	215	4,8
150	40	150	195	15	155	235	5,7
175	40	165	225	15	155	250	7,5
200	40	175	255	15	155	260	8,8
225	40	185	280	15	155	270	11,5
250	40	220	310	15	155	305	13,9
300	45	240	360	20	155	325	22,6
350	45	290	415	25	210	410	27
400	50	335	465	30	210	455	39
450	50	360	520	30	210	480	45
500	55	400	570	30	210	520	56
550	60	420	620	30	210	540	78
600	65	460	675	30	210	580	82



## Standard Measurements GD-6 with Fine Adjustment RDST-32

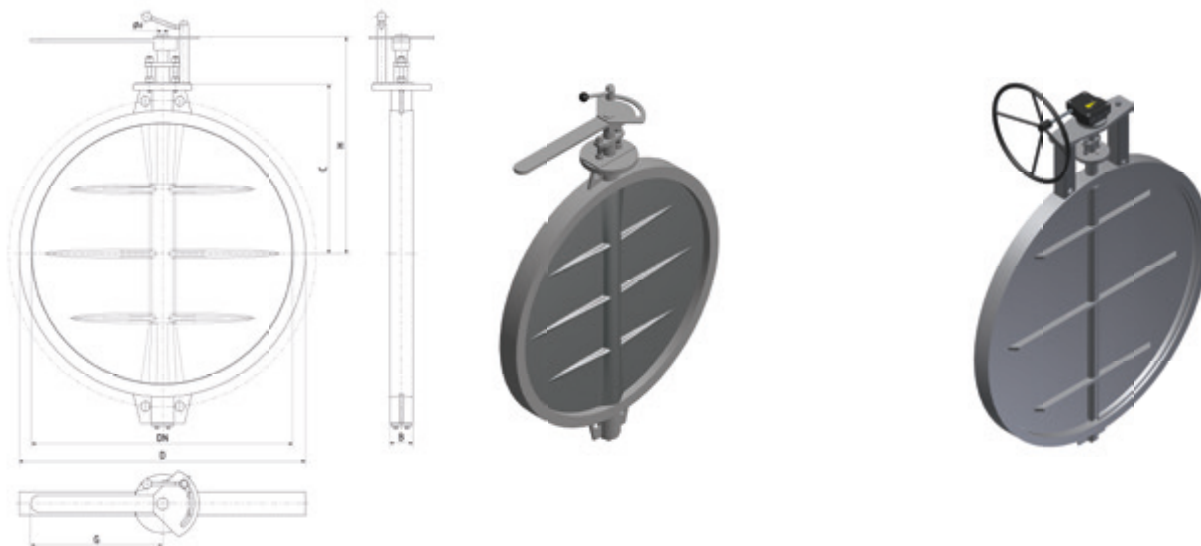

DN	B	C	D	d	G	H	approx. Mass [kg]
15	25	60	44	8	255	165	1
20	25	60	44	8	255	165	1,1
25	25	75	60	10	255	180	1,2
32	25	80	67	10	255	185	1,4
40	25	83	75	10	255	188	1,5
50	25	85	85	10	255	190	1,6
65	30	95	105	12	255	200	2,2
80	30	105	120	12	255	210	2,5
100	30	115	140	12	255	220	2,8
125	35	135	170	12	255	240	4,8
150	40	150	195	15	255	255	5,7
175	40	165	225	15	255	270	7,5
200	40	175	255	15	255	280	8,8
225	40	185	280	15	255	290	11,5
250	40	220	310	15	255	325	13,9
300	45	240	360	20	290	365	22,6
350	45	290	415	25	290	420	27
400	50	335	465	30	290	465	39
450	50	360	520	30	290	490	45
500	55	400	570	30	290	530	56
550	60	420	620	30	290	550	78
600	65	460	675	30	290	590	82
700	70	495	780	35	400	657	120
800	75	545	880	40	400	707	180
900	80	600	980	40	400	762	220
1000	90	670	1080	45	400	832	240
1100	90	730	1180	45	400	892	295
1200	90	790	1295	45	400	952	345
1400	110	920	1510	50	Drive	1120	Contract specific
1600	140	1010	1710	50	Drive	1210	Contract specific
1800	140	1120	1920	50	Drive	1320	Contract specific
2000	140	1230	2130	60	Drive	1430	Contract specific

## Standard Measurements GD-6 with Free Shaft and Fitting

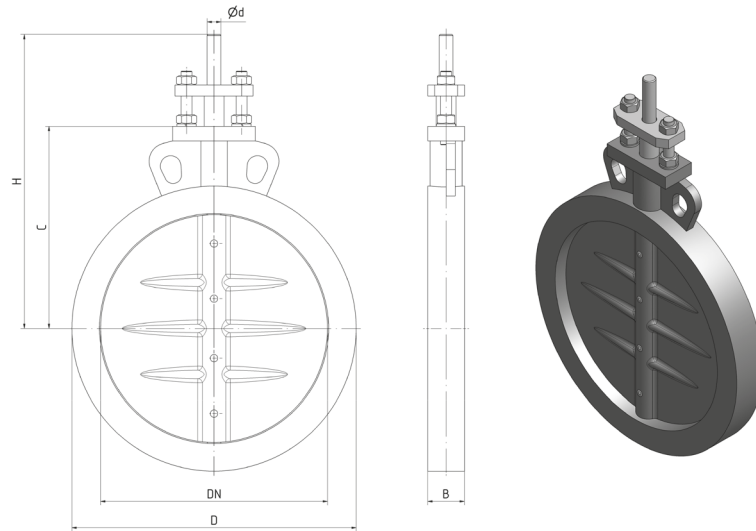

DN	B	C	D	d	H	approx. Mass [kg]
15	25	60	44	8	140	1
20	25	60	44	8	140	1,1
25	25	75	60	10	155	1,2
32	25	80	67	10	160	1,4
40	25	83	75	10	163	1,5
50	25	85	85	10	165	1,6
65	30	95	105	12	175	2,2
80	30	105	120	12	185	2,5
100	30	115	140	12	195	2,8
125	35	135	170	12	225	4,8
150	40	150	195	15	240	5,7
175	40	165	225	15	255	7,5
200	40	175	255	15	265	8,8
225	40	185	280	15	275	11,5
250	40	220	310	15	320	13,9
300	45	240	360	20	340	22,6
350	45	290	415	25	420	27
400	50	335	465	30	465	39
450	50	360	520	30	490	45
500	55	400	570	30	530	56
550	60	420	620	30	550	78
600	65	460	675	30	590	82
700	70	495	780	35	625	120
800	75	545	880	40	675	180
900	80	600	980	40	730	220
1000	90	670	1080	45	820	240
1100	90	730	1180	45	880	295
1200	90	790	1295	45	940	345
1400	110	920	1510	50	1070	Contract specific
1600	140	1010	1710	50	1160	Contract specific
1800	140	1120	1920	50	1270	Contract specific
2000	140	1230	2130	60	1380	Contract specific

## Standard Measurements GD-6 with ISO 5211 Mounting Kit

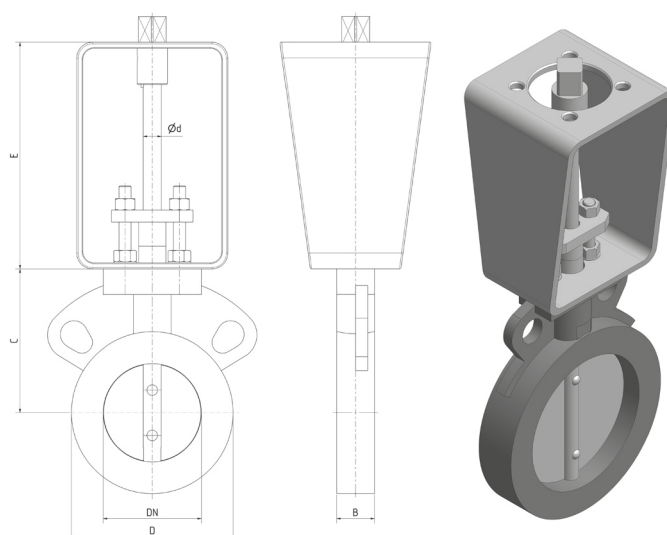

DN	B	C	D	d	E	approx. Mass [kg]
15	25	60	44	8	200 (160)	2,4
20	25	60	44	8	200 (160)	2,5
25	25	75	60	10	200 (160)	2,6
32	25	80	67	10	200 (160)	2,7
40	25	83	75	10	200 (160)	2,8
50	25	85	85	10	200 (160)	2,9
65	30	95	105	12	200 (160)	3,6
80	30	105	120	12	200 (160)	3,9
100	30	115	140	12	200 (160)	4,3
125	35	135	170	12	200 (160)	6,1
150	40	150	195	15	200 (160)	7,7
175	40	165	225	15	200 (160)	9,8
200	40	175	255	15	200 (160)	11,2
225	40	185	280	15	200 (160)	12,9
250	40	220	310	15	200 (160)	16,4
300	45	240	360	20	200 (160)	23,3
350	45	290	415	25	200 (160)	31,9
400	50	335	465	30	200 (160)	44,1
450	50	360	520	30	200 (160)	47
500	55	400	570	30	200 (160)	64,6
550	60	420	620	30	200 (160)	82
600	65	460	675	30	200 (160)	84
700	70	495	780	35	200 (160)	122
800	75	545	880	40	200 (160)	184
900	80	600	980	40	200 (160)	224
1000	90	670	1080	45	200 (160)	256
1100	90	730	1180	45	200 (160)	311
1200	90	790	1295	45	200 (160)	361
1400	110	920	1510	50	Contract specific	Contract specific
1600	140	1010	1710	50	Contract specific	Contract specific
1800	140	1120	1920	50	Contract specific	Contract specific
2000	140	1230	2130	60	Contract specific	Contract specific

## Standard Measurement GD-6 with Double External Bearing

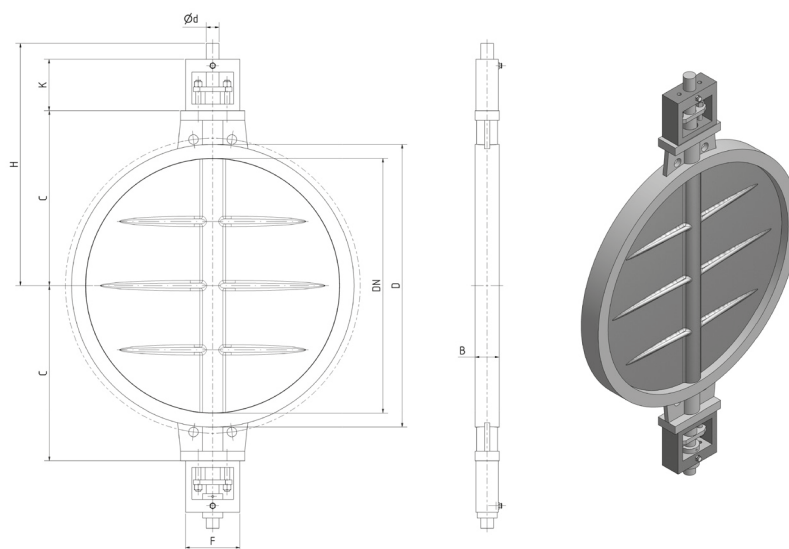

DN	B	C	D	d	K	H	approx. Mass [kg]
15	-	-	-	-	-	-	-
20	-	-	-	-	-	-	-
25	25	75	60	10	160	315	8,6
32	25	80	67	10	160	320	8,8
40	25	83	75	10	160	323	8,9
50	25	85	85	10	160	325	9
65	30	95	105	12	160	335	9,6
80	30	105	120	12	160	345	9,9
100	30	115	140	12	160	355	10,2
125	35	135	170	12	160	385	12,2
150	40	150	195	15	160	400	13
175	40	165	225	15	160	415	15
200	40	175	255	15	160	425	16
225	40	185	280	15	160	435	19
250	40	220	310	15	160	480	21
300	45	240	360	20	160	500	30
350	45	290	415	25	160	580	46
400	50	335	465	30	160	625	58
450	50	360	520	30	160	650	64
500	55	400	570	30	160	690	75
550	60	420	620	30	160	710	97
600	65	460	675	30	160	750	101
700	70	495	780	35	160	785	139
800	75	545	880	40	160	835	200
900	80	600	980	40	160	890	230
1000	90	670	1080	45	160	980	260
1100	90	730	1180	45	160	1040	320
1200	90	790	1295	45	160	1100	370
1400	110	920	1510	50	200	1270	Contract specific
1600	140	1010	1710	50	200	1360	Contract specific
1800	140	1120	1920	50	200	1470	Contract specific
2000	140	1230	2130	60	200	1580	Contract specific

## Kv-values of the GD-6

$\alpha$ [°]	DN 50	DN 65	DN 80	DN 100	DN 125	DN 150	DN 200	DN 250	DN 300
5 °	1	2	3	4	6	9	16	26	37
10 °	2	3	5	8	12	18	31	49	70
15 °	4	6	9	14	22	32	57	88	127
20 °	6	9	14	22	35	50	89	139	201
25 °	8	14	21	32	50	72	128	201	289
30 °	11	18	28	44	68	98	175	273	393
35 °	14	24	37	58	90	130	231	361	520
40 °	19	32	48	76	118	170	302	472	680
45 °	25	42	63	98	154	222	394	616	886
50 °	32	54	82	129	201	290	515	804	1158
55 °	42	71	108	169	263	379	674	1054	1518
60 °	55	93	142	221	346	498	885	1383	1991
65 °	73	123	186	290	453	653	1160	1813	2610
70 °	95	160	243	380	593	854	1519	2373	3417
75 °	123	208	315	492	769	1108	1969	3077	4431
80 °	166	281	425	665	1039	1496	2659	4155	5984
85 °	207	349	529	827	1292	1861	3308	5169	7443
90 °	227	384	582	909	1420	2045	3635	5680	8179

$\alpha$ [°]	DN 350	DN 400	DN 450	DN 500	DN 600	DN 700	DN 800	DN 900	DN 1000
5 °	50	65	83	102	147	200	261	331	408
10 °	96	125	158	196	282	384	501	634	783
15 °	173	226	286	353	509	693	905	1145	1414
20 °	273	357	452	558	803	1093	1428	1807	2231
25 °	393	514	650	803	1156	1573	2055	2600	3210
30 °	536	699	885	1093	1574	2142	2798	3541	4372
35 °	708	925	1171	1446	2082	2833	3701	4684	5782
40 °	926	1209	1530	1889	2720	3702	4835	6120	7555
45 °	1206	1576	1994	2462	3546	4826	6303	7977	9849
50 °	1576	2059	2606	3217	4632	6305	8235	10423	12867
55 °	2066	2698	3414	4215	6070	8262	10791	13658	16861
60 °	2711	3540	4481	5532	7966	10842	14161	17923	22127
65 °	3553	4641	5874	7251	10442	14213	18564	23494	29005
70 °	4651	6075	7688	9491	13668	18603	24298	30752	37966
75 °	6031	7878	9970	12309	17725	24126	31511	39881	49236
80 °	8144	10637	13463	16621	23934	32577	42549	53852	66483
85 °	10131	13232	16746	20675	29771	40522	52927	66986	82699
90 °	11132	14540	18402	22718	32714	44527	58158	73607	90872

Please contact us should you need the valves in larger sizes.

## Custom Designs

According to your individual needs, we produce the GD-6 in different material combinations and for different actuators and applications.

GD-6  
With side mounted  
actuator



GD-6  
Reduced  
diameter



GD-6  
Brush valve  
for flow elements



## Glossary

<b>Butterfly Valve</b>	A butterfly valve consists of a body and is for flow regulation. Clamped between flanges.
<b>Centering Aid</b>	Lugs right and left of the operating side shaft outlet of the valve. They ensure easier and more precise installation into a pipeline.
<b>Closing</b>	Contact of the valve disk with the body. Possible seals: Striking, swing through, with stop bar and stop bar with seals.
<b>Coupling</b>	Connection between the actuator and the valve shaft.
<b>Electric Operation</b>	Electric operation of the valve. Control over 4 .. 20 mA-signal possible. Wide ranging optional accessories available.
<b>Element</b>	Element flowing through the valve. (Gas, liquid, etc.)
<b>External Seal</b>	Used at high temperatures to guarantee the turning of the valve at all operating conditions.
<b>Fine Adjustment</b>	Lever which has a free swing variance of 90° and is movable per wing screw or clamp lever into any position.
<b>Fitting Key</b>	Metallic adaption of the shaft to the actuator. This is a side connected metal lug on the shaft. Serves for power transfer from the actuator to the shaft.
<b>Flange Bearing</b>	Serves as transmission of high torques.
<b>Four Cornered Shaft</b>	Serves for the adaption of the shaft to the required connection of the actuator.
<b>Grid Handle</b>	Gear teeth on a nut screwed scale provides the possibility of a gradual adjustment of the valve disk. The catch of the hand lever locks into the teeth. 16 positions between 0 and 90 ° are fixed.
<b>Hand Operation</b>	With grid handle, fine adjustment or worm gear. Depending on installation.
<b>Hydraulic Operation</b>	Operates with a hydraulic cylinder. Special: Good power distribution in limited spaces.
<b>Impermeability</b>	Shows how impermeable the flow is inside the valve. (Dependant on construction, classified in leakage rates).

### GD-6

<b>Inner Sizing</b>	Internal flow area of the valve.
<b>Installation Position</b>	Describes the horizontal or vertical position of the shafts of the valve once installed.
<b>ISO 5211</b>	Norm regulates the attachment measurements for actuators to attachment parts onto valves.
<b>Kv 90°</b>	Flow in a fully open valve disk.
<b>Lever System</b>	It regulates two or more valves with an actuator.
<b>Mounting Kit</b>	Normed part for mounting actuators.
<b>Nominal Size</b>	Size of the inner measurement of the valve.
<b>Operation</b>	Operation of the valve. Possible operation: manual, pneumatic- und electric actuators (as standard). All further adaptations available as per customer needs.
<b>Operational Pressure</b>	Pressure in the pipeline which works on the valve.
<b>Operational Temperature</b>	Temperature of the element in the pipeline.
<b>Packing Gasket</b>	Serves as the seal between the valve and shaft exit from the valve body. Can be produced in various ways. (EPDM, PTFE, TA-Luft eg.)
<b>Pneumatic Operation</b>	Opening of the disk in the valve with a pneumatic actuator. With or without a spring setting. Control possible with a positioner.
<b>RDST-32</b>	Infinitely adjustable fine adjustment for larger valves.
<b>Safety Position</b>	This is decided by the customer. Defines the position of the valve in an emergency.
<b>Seal</b>	Flexible material in the valve. To improve the impermeability.
<b>Sealing Air</b>	Used to seal the shaft up to 100%.
<b>Service</b>	Defines the regular necessary readjustments (readjustment of the packaging, etc.). For the maintenance plan please see operating and maintenance manual.
<b>SFD-6</b>	Infinitely adjustable fine adjustment with a manual handle, used in smaller valves.
<b>Shaft Bearing</b>	Bears of the shafts in the body.
<b>Slide Bearing</b>	Turned sleeve, e.g. from red brass.
<b>Step-seated</b>	Disk valve fitted in the body of the valve and stops the flow.
<b>Stop bar</b>	Metallic valve stop in the valve. Serves to seal the valve.
<b>Swing-through</b>	Valve without seals between the disk and body with defined ring gap.
<b>TA-Luft</b>	German Clean Air Act (§48 BImSchG). Using a TA-Luft packing ensures 100% seal of the shaft bushing to the outside.



## Certificates

We are certified for the following processes:

- ISO 9001
- AD 2000 HPO
- EN 3834-2
- SIL
- ATEX

## Services for the Valves

We are happy to support you with various services to optimize the use of the valve.

- Determination of sound level
- Expertise on earthquake safety
- Strength calculation
- FEM calculation
- Leakage calculation
- Flow simulations
- Assembly and test run of your actuator
- Lacquering to your liking



Test station at JASTA-ARMATUREN

**JASTA-ARMATUREN** GmbH & Co. KG

Levinstr. 156-160  
45356 Essen  
Germany

Phone: +49 - (0)201 - 86602-0  
Fax: +49 - (0)201 - 86602-21

[www.jasta-armaturen.com](http://www.jasta-armaturen.com)  
[info@jasta-armaturen.com](mailto:info@jasta-armaturen.com)