

3 WAY PNEUMATIC CONTROL VALVE TYPE 7562P

Description

Three ways pneumatic control valve especially designed for a wide range of fluids like water, thermal oil, etc... These pneumatic valves offer an optimized and modular solution for industrial process.

Characteristics

DN15 to DN300

Material: Steel 1.0619

Stainless steel 1.4408

Iron cast GJL 250 (DN125 – DN200)

Iron cast GJS 400-18 (DN250 - DN300)

Flanges ISO PN16, 25, 40 – Class150

Design ANSI B16.34 PN50

Temperature Range : -60°C to +400°C

Kvs from 3,9 to 1450

Function : Mixing or Diverting

Stainless steel – Linear characteristic

PTFE/Graphite



Options

Pure graphite packing

Stainless steel bellow

Soft seal cone

High temperature insulation

Flanges with grooves

Third way facing (See H6-H7)

Actuator

Pneumatic Actuators Types PA35, PA60, MA41, MA60

Air supply max 6 bar

Surface active area from 180 to 1730 cm² (See pneumatic actuator data sheet)

Particular advantages

7562P control valves are designed and built in France, ensure you an excellent reliability related to exceptional performance.

How to order

7562P DN80 PN40 KVs 100 actuator PA60

Certification

DESP; ATEX II 2 G/D; ISO9001 / PED; ATEX II 2 G/D; ISO9001

Cone Types

Mixing cone (Y)

Characteristic : Linear

Material : 1.4404

Sealing : Metallic tight

Tightness class : Classe III (<0.1% Kvs) ANSI B16-104/ FCI 70-2-2006 (EN 60534-4)

Application : Mixing Three ways valves (standard)

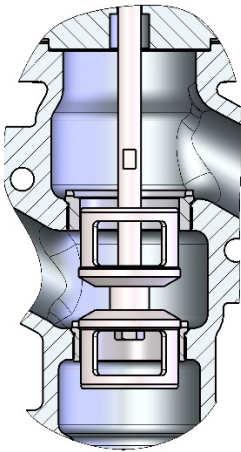

CLAPET MÉLANGEUR
MIXING CONE (Y)

Spindle in without signal

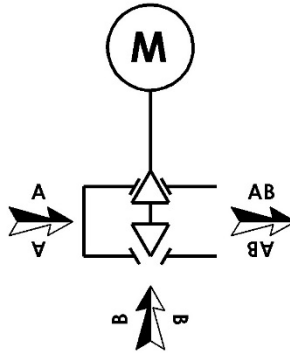

Voie/Way A→AB
NF par manque de signal
NC without signal

Spindle out without signal

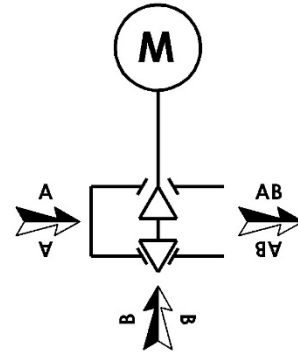

Voie/Way B→AB
NF par manque de signal
NC without signal

Diverting cone (Z)

Characteristic : Linear

Material : 1.4404

Sealing : Metallic tight

Tightness Class : Classe III (<0.1% Kvs) ANSI B16-104/ FCI 70-2-2006 (EN 60534-4)

Application : Diverting Three Ways Valves

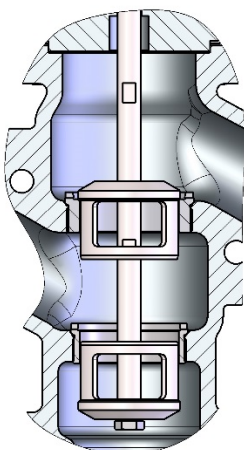

CLAPET RÉPARTITEUR
DIVERTING CONE (Z)

Spindle in without signal

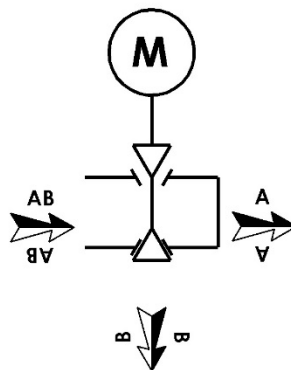

Voie/Way AB→B
NF par manque de signal
NC without signal

Spindle out without signal

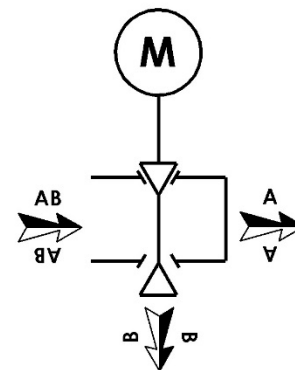

Voie/Way AB→A
NF par manque de signal
NC without signal

Packing

PTFE/Graphite

Chevron Ring With Spring
 Max temperature : 250°C,
 Max pressure : 50 bar
 Water, steam, oil, gaz...
 See pressure/temperature charts

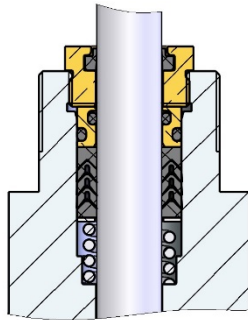

**GARNITURE PTFE CHARGE GRAPHITE
 PTFE WITH GRAPHITE PACKING**

Pure Graphite (option)

Max temperature : 400°C,
 Max pressure : 50 bar
 Water, steam, etc...
 See pressure/temperature charts

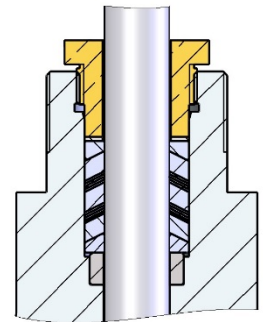

**GARNITURE GRAPHITE
 PURE GRAPHITE PACKING**

Stainless Steel Bellows with graphite safety stuffing box (option)

Max Temperature : 350°C,
 Max pressure : 20 bar
 See pressure / Temperature charts

High Temperature insulation (option)

Max Temperature : 400°C,
 Max pressure : 50 bar
 See pressure/temperature charts

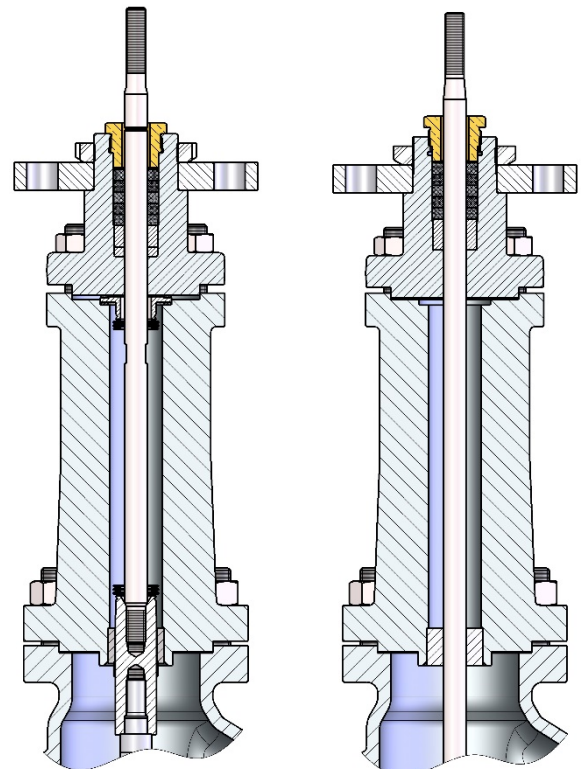

STAINLESS STEEL BELLOWS SEALING

HIGH TEMPERATURE INSULATION

Temperature limits

Temperature (°C)	-60	-25	-10	20	100	200	250	350	400
PTFE/Graphite Packing									
Graphite Packing									
Cold Packing									
Stainless steel bellows									
Insulation									
Stuffing box heater									
Steel body									
Stainless Steel body									
Cast iron body									

General characteristics

DN	15	20	25	32	40	50	65	80	100	125	150	200	250	300										
	Ø Siège / Seat																							
Type Y	25	25	32	32	50	50	65	80	100	100	125	125	150	125	150	200	150	200	250	200	250	300		
Type Z	25	25	32	32	50	50	65	80/65	100/80	100	125	125	150	125	150	200	150	200	250	150	200	250		
	Courses / Stroke																							
Type Y	15	15	20	20	20	20	20	40	40	40	40	40	50	50	50	80	60	60	80					
Type Z	15	15	20	20	20	20	20	30/40*	30/40*	40	40	40	50			80			80					
	Kvs																							
Type Y	3,9	5,5	10	12	29	34	60	91	148	155	230	230	325	230	325	630	360	715	970	720	1100	1450		
Type Z	3,9	5,5	10	12	29	34	60	91	148	155	230	230	325	230	325	630	360	715	970	720	1100	1450		
									Voie B															

* Possible value in option on way B with compensation flange

Differential Pressure Values

DN			15	20	25	32	40	50	65	80	100	125		150		200														
Stroke			15	15	20	20	20	20	20	40	40	40	40	40	40	40	40	50												
Seat Ø			25	25	32	32	50	50	65	80	100	100	125	125	150	125	150	200												
Kvs			3,9	5,5	10	12	29	34	60	91	148	155	230	230	325	230	325	630												
Actuator	Spring	Alim. Mini air supply	Maxi Differential Pressure with positioner																											
			PA35 B6 C : 38 mm			2G		1,4		11,0		5,8		2,4		1,4														
0,5-0,9		0,4-0,9																												
5G		2,5				25,9		12,7		5,2		3,1																		
		0,7-1,8				0,6-1,7																								
5G		6				40																								
		1,6-2,1																												
6G		6						35,1		14,4		8,5																		
		1,9-3,1																												
PA60 A6 C : 43 mm						3R		1,4		20		8,2		4,9		1		0,6												
								0,4-0,9				0,3-1,1																		
						3S		2,5		40		16,6		9,8																
								0,8-1,6																						
						3S		4,5						18,2																
								1,6-2,4																						
						4S		5,5						24,6		9,7		6,2												
								2,1-3,1		1-3,1																				
PA60 C6 C : 63 mm			3G		1,4				9,1		5,4		1,9		1,2															
					0,5-0,8				0,3-1																					
			3S		2,5				19,7		11,7		3,1		2															
					1,1-1,8				0,4-1,9																					
			4S		6						25,9																			
					2,4-3,4																									
			6G		3,5										2,7		1,5		1,5		0,9		2,8		0,8		0,3			
					0,9-2,2																									
6S		6								10,8		6,9		4,6		2,7		2,7		1,8		3,9		1,7		0,8				
		1,4-4,4				1,2-4,2																								
MA41 B6 C : 62 mm			4G		1,4				21,8		12,9		5,5		3,5		1,8		0,9		0,9		0,5		1,2		0,4		0,1	
					0,5-0,8				0,4-1				0,5-1,1																	
			6S		2,5 *3,5				40		21,9		17,1*		10,9*		9*		5,6*		5,6*		3,7*		6,9		3,6*		1,9*	
					1-1,6				1-2,2																					
			10S		6								32,2		20,6		16,9		10,6		10,6		7,2		12,3		7,1		3,8	
1,6-3,6					1,7-3,5																									
MA60 G6 C : 59 mm			4S		2,5								18,1		11,4		11,4		7,7		12,4		7,6		4,1					
					0,9-1,5																									
			12S		6										40		28,8		28,8		19,9		30		19,7		10,9			
2-3,5																														

Dimensions DN15 - DN100

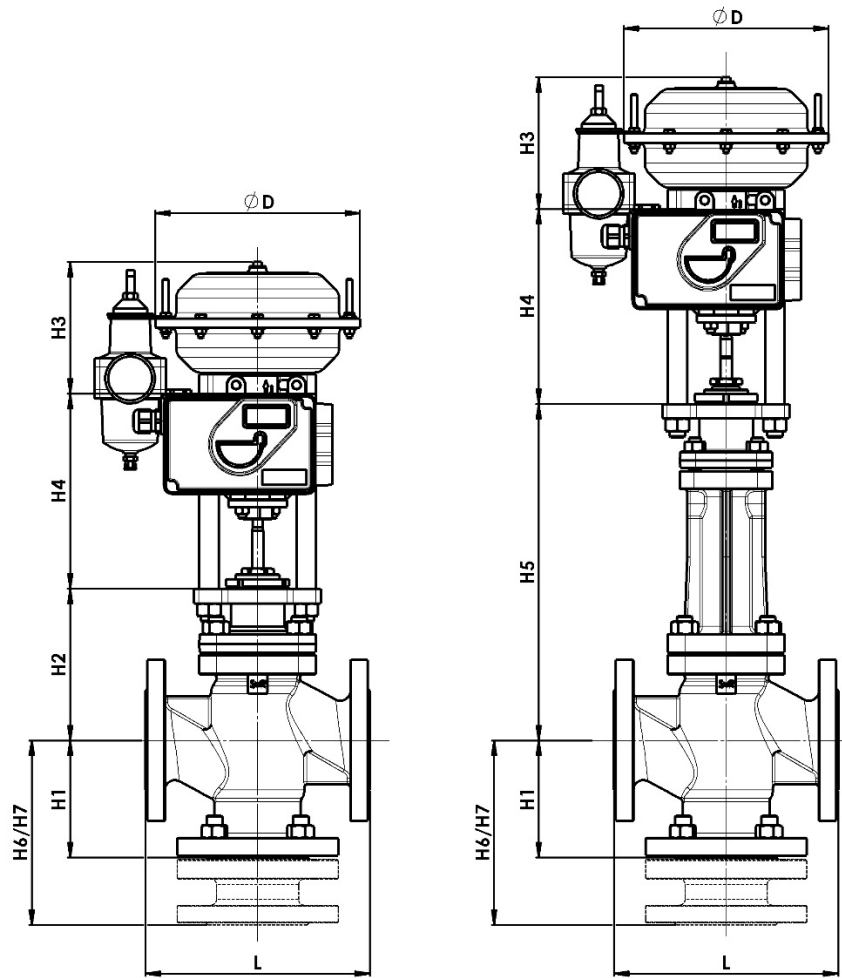

DN	15	20	25	32	40	50	65	80	100
L	130	150	160	180	200	230	290	310	350
H1	70	80	85	100	105	120	130	140	150
H2	139	128	139	138	160	156	162	178	198
H5	327	320	326	325	350	345	344	353	381
H4 (max)	200	200	200	200	200	200	200	200	200
H6	150	150	150	160	175	190	225	240	250
H7	/	110	140	140	162	162	165	215	240
Mass (kg) – Standard	6	6,5	10	12	15	19	26	30	49
Mass (kg) – Standard + Ext.	8	8,5	13	15	20	24	34	42	61
Mass (kg) – Standard + Comp*	7,5	8	13	16	20	25	34	40	62
Mass (kg) – Standard + Ext. + Comp*	9,5	10	16	19	25	30	42	52	74

* Extension flange

All dimensions in mm

	PA35-B6	PA60-A6	PA60-C6	MA41-A6	MA41-B6	MA41-C6
ØD	210	310	310	420	420	420
H3	125	153	173	224	242	354
Masse / Mass (kg)	5,2	10,5	12,5	55	55	72

All dimensions in mm

Dimensions DN125 – DN200

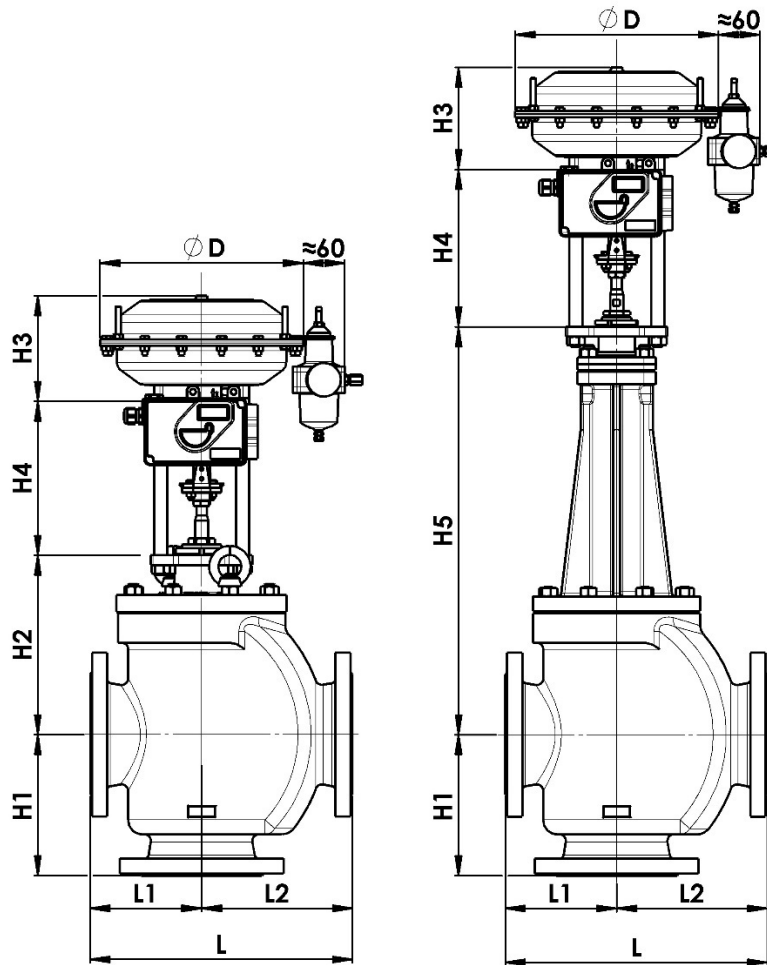

DN	125	150	200
L	400	480	600
L1	170	225	275
L2	230	255	325
H1	215	240	290
H2	274	286	330
H5	622	577	676
H4 (max)	260	260	260
Mass (kg) – Standard	132	140	210
Mass (kg) – Standard + Ext.	153	164	244

All dimensions in mm

	PA35-B6	PA60-A6	PA60-C6	MA41-B6	MA41-G6
ØD	210	310	310	420	600
H3	125	153	173	242	383
Mass (kg)	5,2	10,5	12,5	55	160

All dimensions in mm

Dimensions DN250 - DN300

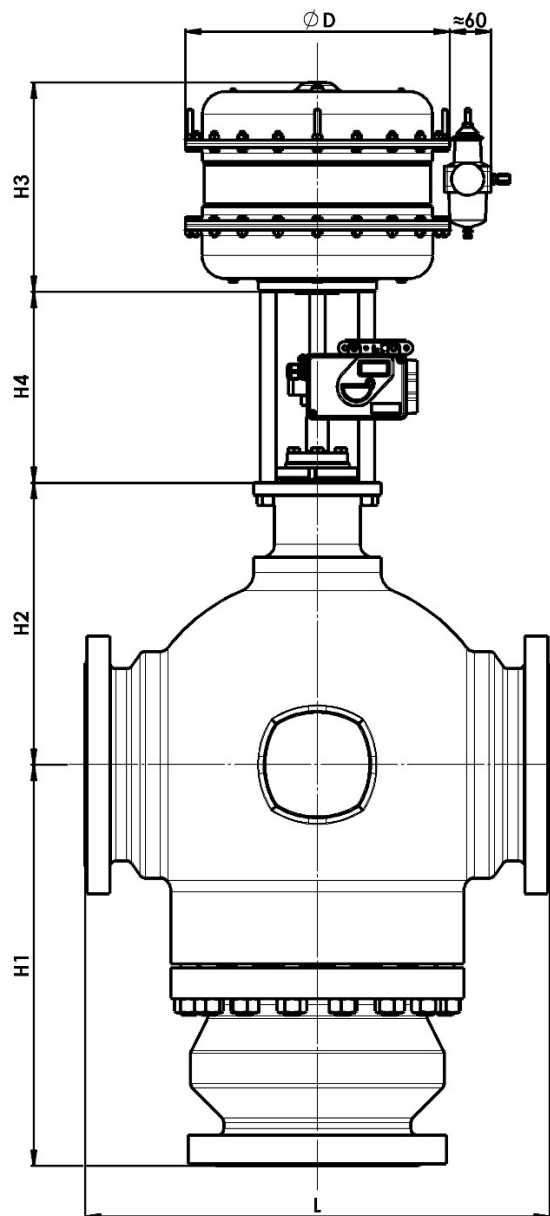

DN	250	300
L	730	850
H1	630	700
H2	800	800
Mass (kg) - Standard	580	600

All dimensions in mm

	PA60-A6	PA60-C6	MA41-B6	MA41-C6	MA41-G6
$\varnothing D$	310	310	420	420	600
H3	153	173	242	352	383
Mass (kg)	10,5	12,5	55	76	160

All dimensions in mm

Part List – DN15 - DN100

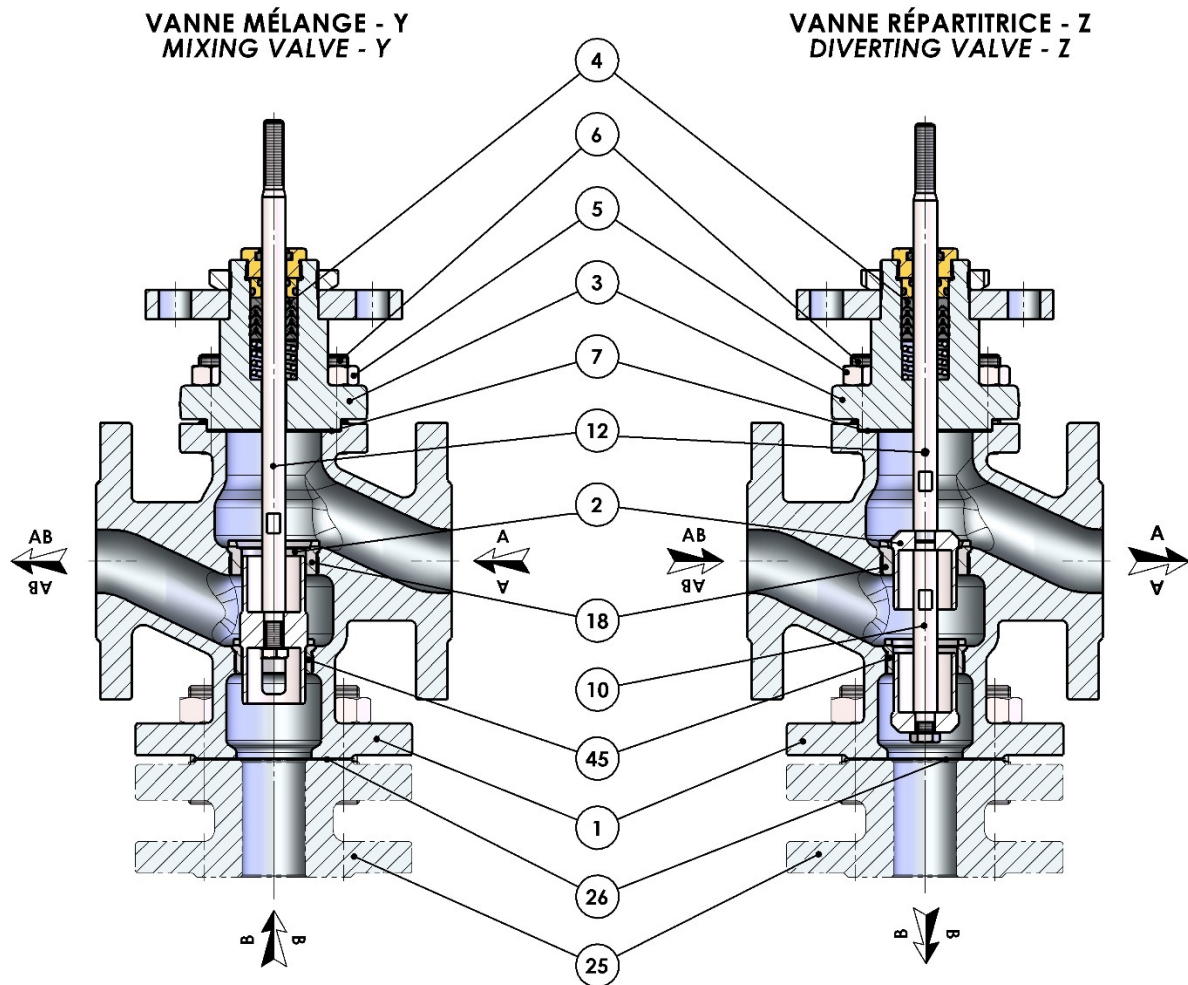

Rep./Item	Description	Material
1	Body	1.0619- A216 WCB - 1.4408- A351 CF8M
2	Cone	Stainless steel
3	Cover	1.0570 - 1.0619 / 1.4404 - 1.4408
4*	Stuffing box	Brass - Stainless steel
5	Nut	8.8 / A2-70
6	Stud	8.8 / A2-70
7*	Gasket	Graphite
10	Stem	1.4404
12	Intermediate stem	1.4404
18	Upper seat	Hardened stainless steel
25	Flange	S355 – 1.4404
26*	Gasket	Graphite
45	Lower seat	Hardened stainless steel

*Spare List

Part List – DN100 – DN200

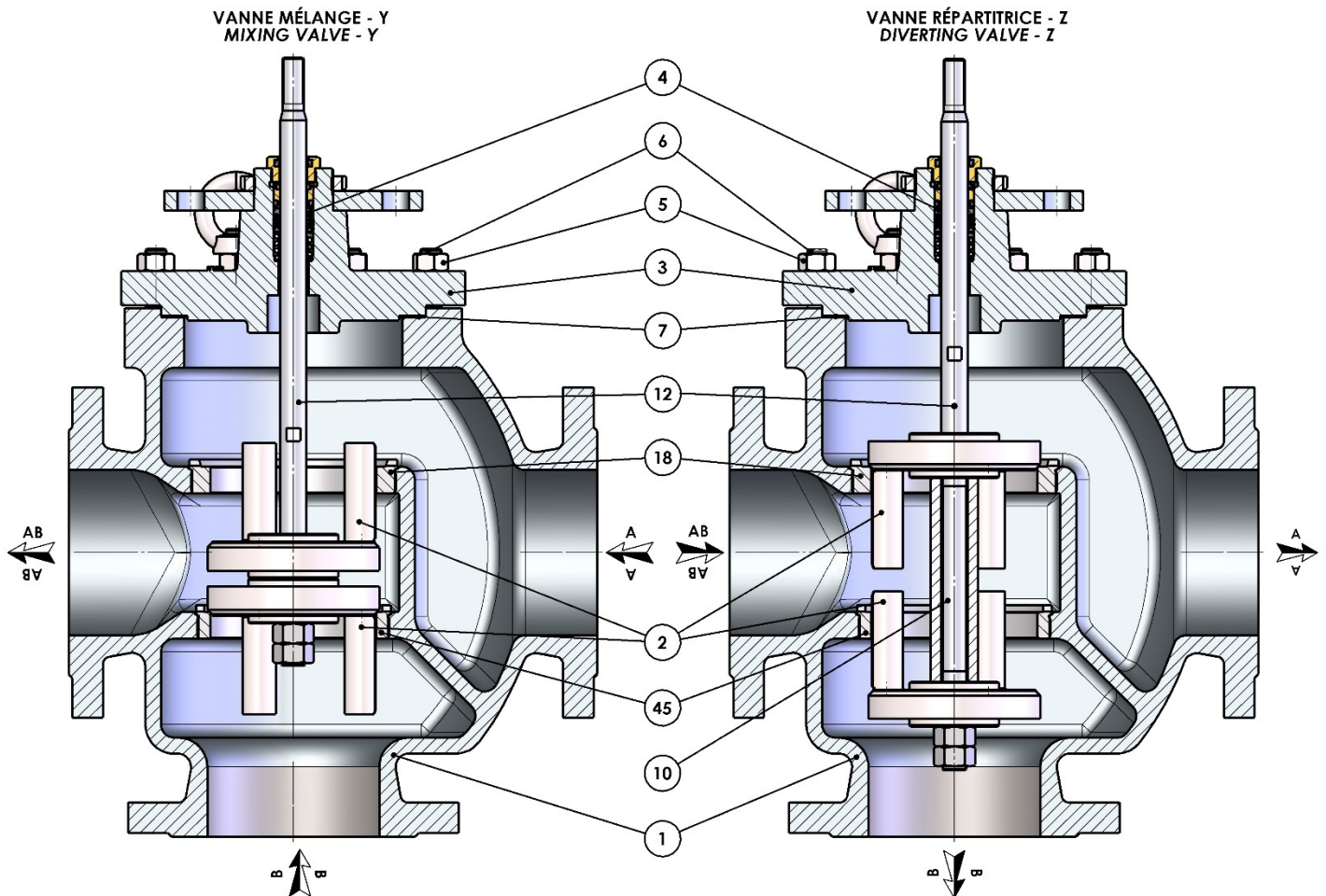

Item	Description	Material
1	Body	1.0619- A216 WCB - 1.4408- A351 CF8M
2	Cone	Stainless steel
3	Cover	1.0570 - 1.0619 / 1.4404 - 1.4408
4*	Stuffing box	Brass - Stainless steel
5	Nut	8.8 / A2-70
6	Stud	8.8 / A2-70
7*	Gasket	Graphite
10	Stem	1.4404
12	Intermediate stem	1.4404
18	Upper seat	Hardened stainless steel
45	Lower seat	Hardened stainless steel

*Spare List

Part list – DN250 – DN300

VANNE MÉLANGE - Y
MIXING VALVE - Y

VANNE RÉPARTITRICE - Z
DIVERTING VALVE - Z

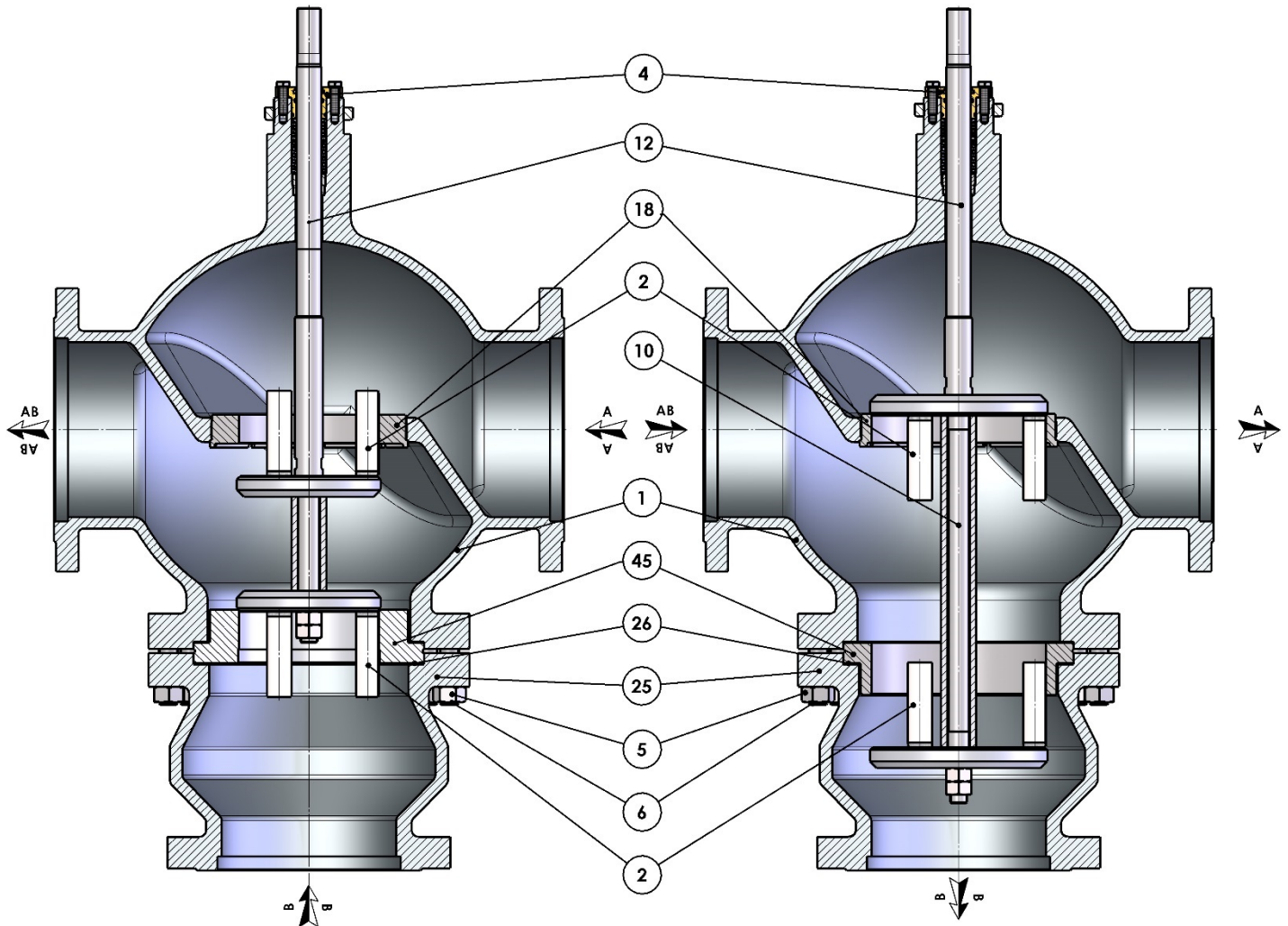

Item	Description	Material
1	Body	1.0619 / 1.4408 / GGG40,3
2	Cone	Stainless steel
4*	Stuffing box	Brass - Stainless steel
5	Nut	8.8 / A2-70
6	Stud	8.8 / A2-70
7*	Gasket	Graphite
10	Stem	1.4404
12	Intermediate stem	1.4404
18	Upper seat	Hardened stainless steel
25	Flange	1.0619 / 1.4408 / 5.3105
26*	Gasket	Graphite
45	Lower seat	Hardened stainless steel

* Spare List

Pressure/Temperature Chart

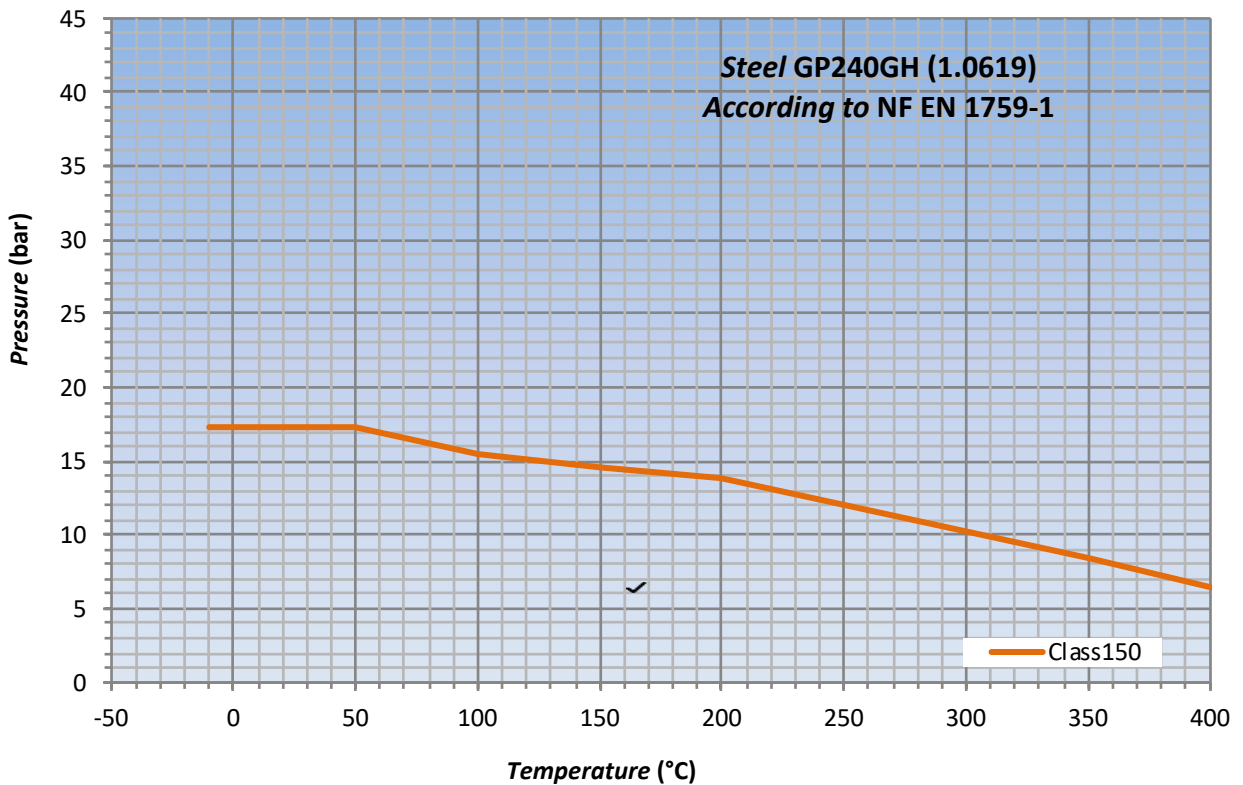
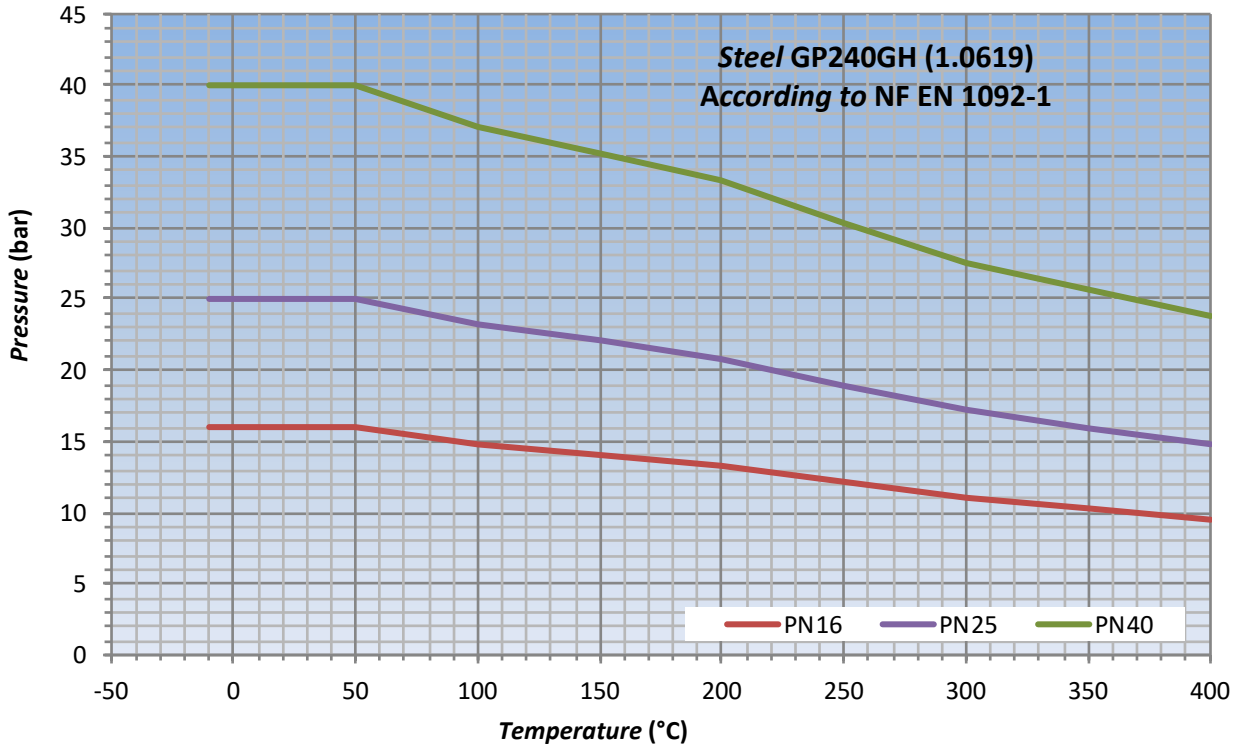

Pressure/Temperature Chart

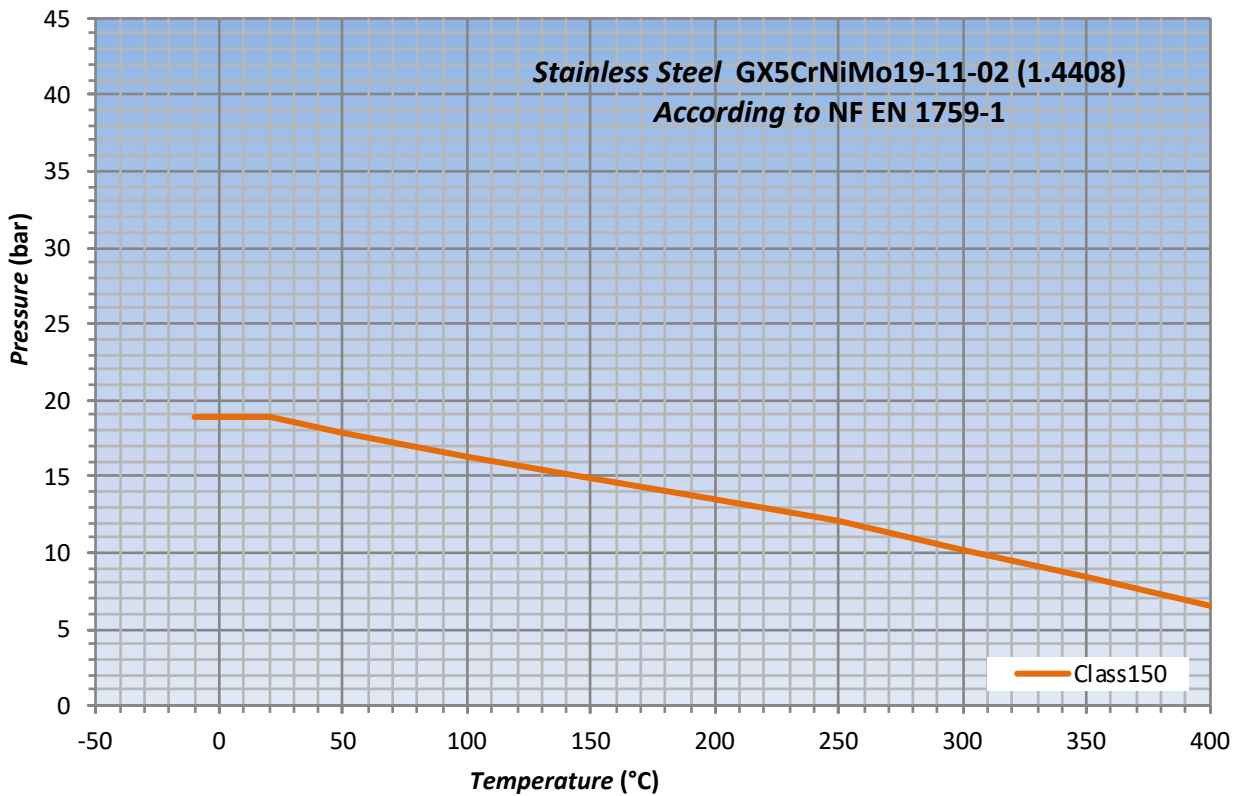
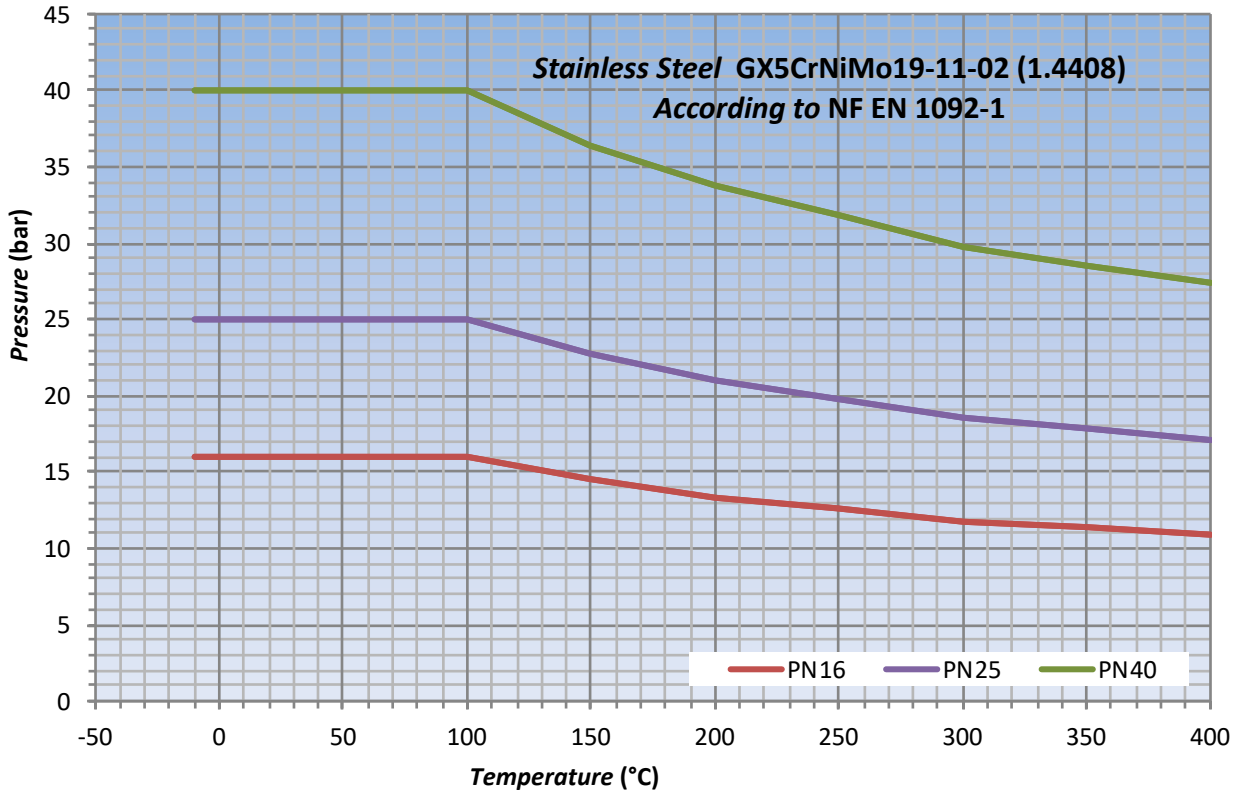

Pressure / Temperature Chart

